

# HDF series - PARALLEL GRIPPER

(Thin type)

Operation specification and Ordering expression

CHELIC PNEUMATIC

## Internal structure

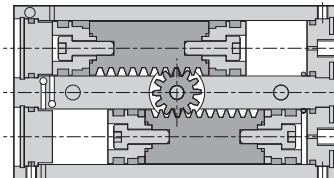
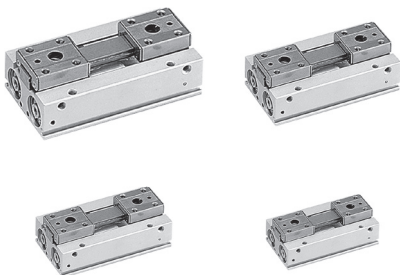

## Specification

New

Item	Model	HDF-8	HDF-12	HDF-16	HDF-20
Bore size		Ø8	Ø12	Ø16	Ø20
Type of operation		Double acting			
Fluid		Air			
Pressure range		1.5 ~ 7 ( 150 ~ 700 )			
Range of service temperature	kgf/cm <sup>2</sup> (kpa)	0 ~ 60			
Max. operation frequency	min	180			
Lubrication	Cylinder	Lubrication free			
	Lever section	Required ( Apply Lubricating oil )			
Lever open/ close angles		8、16、32	12、24、48	16、32、64	20、40、80
Port size		M5 × 0.8P			
Magnet device	mm	With magnet			

## How to order

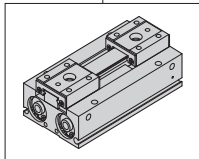
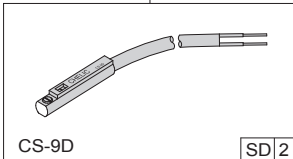
<b>HDF</b>	<b>16</b>	<b>32</b>	<b>SD</b>	<b>2</b>
Model	Bore size	Stroke	Sensor switch	
	8 - Ø 8 mm 12 - Ø 12 mm 16 - Ø 16 mm 20 - Ø 20 mm	Ø8 - 8、16、32 mm Ø12 - 12、24、48 mm Ø16 - 16、32、64 mm Ø20 - 20、40、80 mm		

HDF :  
Parallel Gripper

None : without sensor

**SD** : Sensor code (CS-9D)

**SB** : Sensor code (CS-9B)

**SH** : Sensor code (CS-9H)

**SDN** : Sensor code (CS-9DN)

**SDP** : Sensor code (CS-9DP)

**SG** : Sensor code (CS-8G)

**SGN** : Sensor code (CS-8GN)

**SGP** : Sensor code (CS-8GP)

※ CS-9H use for  
voltage AC/DC 5~240V

**2** : Number of sensor  
1=1 PCS  
2=2 PCS

**HDS**  
Angular  
Gripper

**HDM**  
180°Angular  
Gripper

**HDP**  
Parallel  
Gripper

**HDK**  
Parallel  
Gripper

**HDF**  
Parallel  
Gripper

**HDZ**  
Parallel  
Gripper

**HDZL**  
Parallel  
Gripper

**HDW**  
Parallel  
Gripper

**HDL**  
Gripper

**HDT**  
Gripper

**HDR**  
Three  
Finger  
Gripper

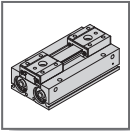

# HDF series - PARALLEL GRIPPER

Model selection

( Thin type )

CHELIC PNEUMATIC

## Selection procedure

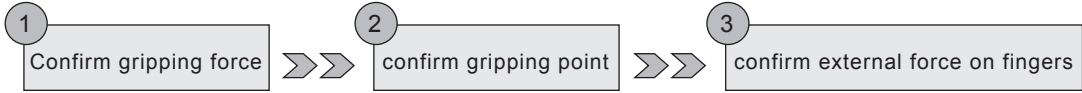

## Step 1

- Confirm gripping force : HDF series
- Expressing the effective gripping force

### External gripping

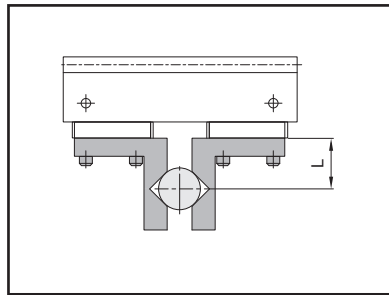
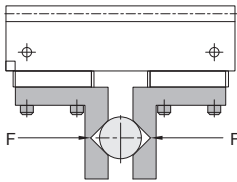

### Internal gripping

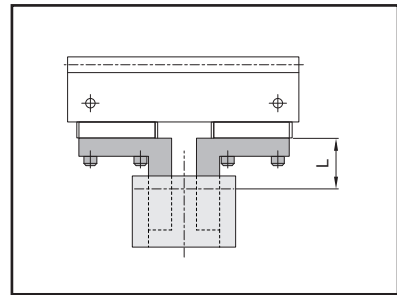

### HDF - 8

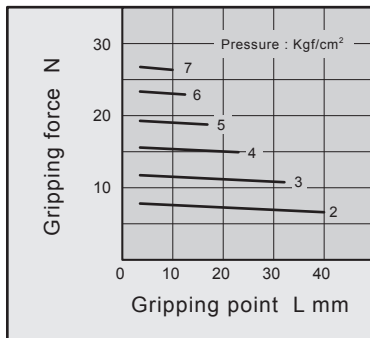

### HDF - 12

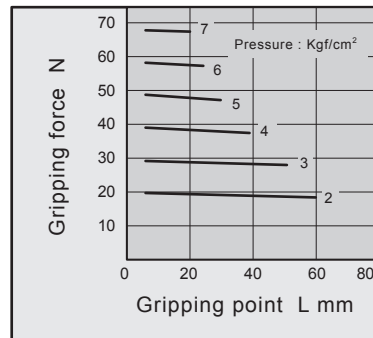

### HDF - 16

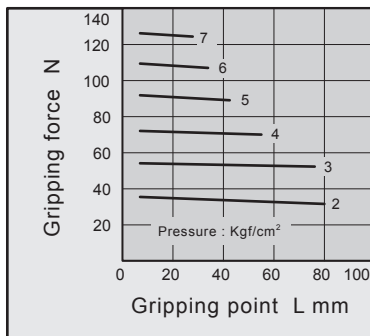

### HDF - 20

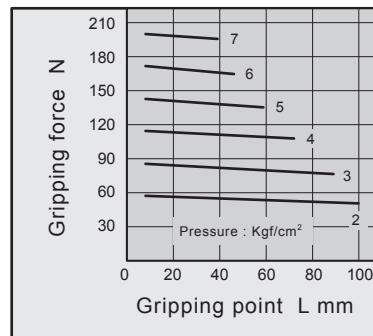

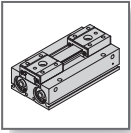

# HDF series - PARALLEL GRIPPER

## Model selection

(Thin type)

CHELIC PNEUMATIC

### Step 2

- Confirmation of the gripping position : HDF series
- The gripping position of a workpiece should be operated so that the amount of overhang (H) will stay the range given in the graphs below.
- If the gripping position of a workpiece over the range limits, this will have an adverse effect on the life of the gripper

### External gripping

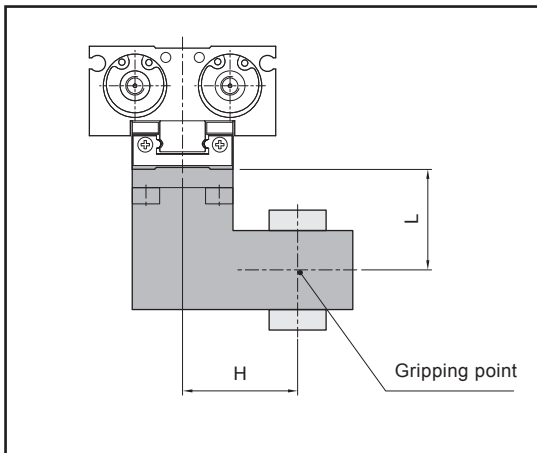

### Internal gripping

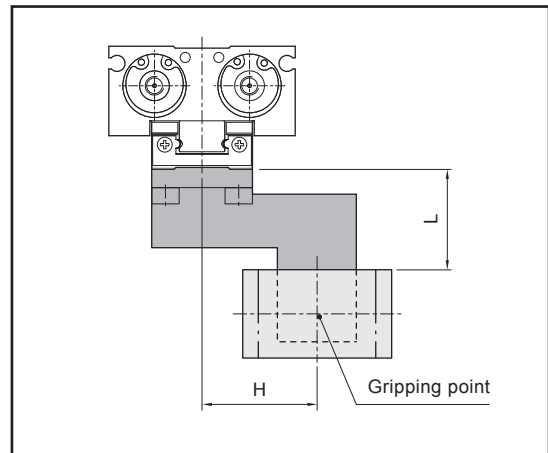

HDF - 8

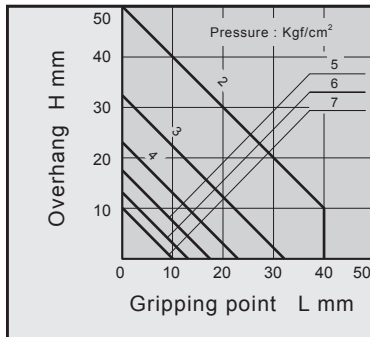

HDF - 16

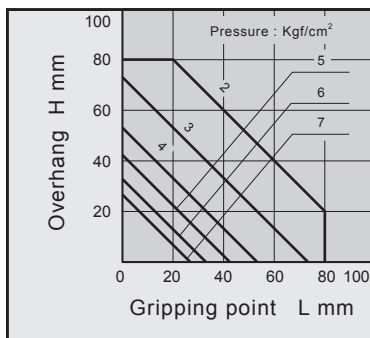

HDF - 12

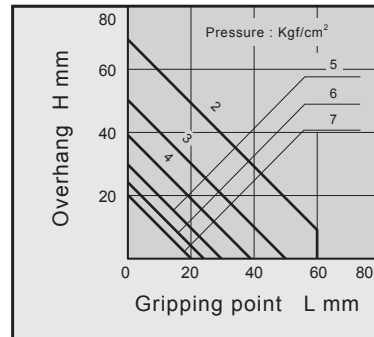

HDF - 20

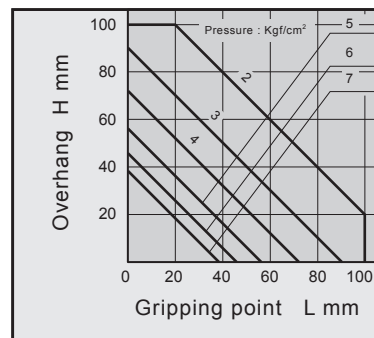

**HDS**  
Angular  
Gripper

**HDM**  
180° Angular  
Gripper

**HDP**  
Parallel  
Gripper

**HDK**  
Parallel  
Gripper

**HDF**  
Parallel  
Gripper

**HDZ**  
Parallel  
Gripper

**HDZL**  
Parallel  
Gripper

**HDW**  
Parallel  
Gripper

**HDL**  
Gripper

**HDT**  
Gripper

**HDR**  
Three  
Finger  
Gripper

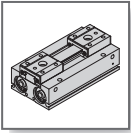

# HDF series - PARALLEL GRIPPER

Model selection

( Thin type )

CHELIC PNEUMATIC

## Step 3

Confirmation of external force on fingers : HDF series

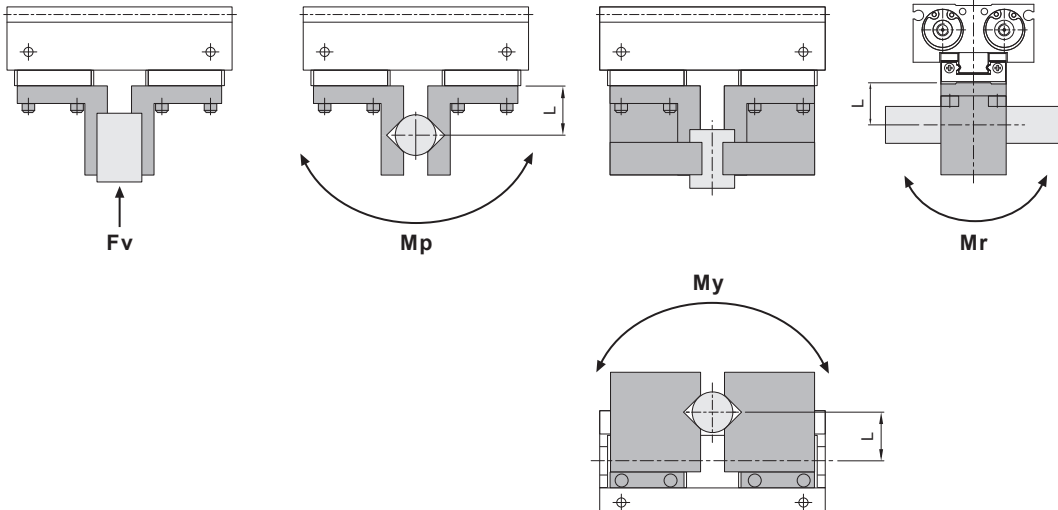

L : Distance to the point at which the load is applied

Model	Allowable vertical load Fv(N)	Maximum allowable moment		
		Mp (N · m)	My (N · m)	Mr (N · m)
HDF - 8	58	0.26	0.26	0.53
HDF - 12	98	0.68	0.68	1.4
HDF - 16	176	1.4	1.4	2.8
HDF - 20	294	2	2	4

Note : the load and moment values in the table is static values

Calculation of allowable external force (when moment load is applied)	Calculation examples
$\frac{M(\text{Maximum allowable moment}) (N \cdot m)}{L \times 10^{-3}}$	<p>When a load <math>f = 10 \text{ N}</math> operating, which applies pitch moment to point 30mm from the end of the HDF - 8</p> $\text{Allowable load } F = \frac{0.53}{10 \times 10^{-3}} = 17.6(\text{N})$ <p>17.6 &gt; 10 can be used</p>

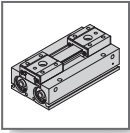

# HDF series - PARALLEL GRIPPER

## Components and Material list

(Thin type)

CHELIC PNEUMATIC

### Internal structure

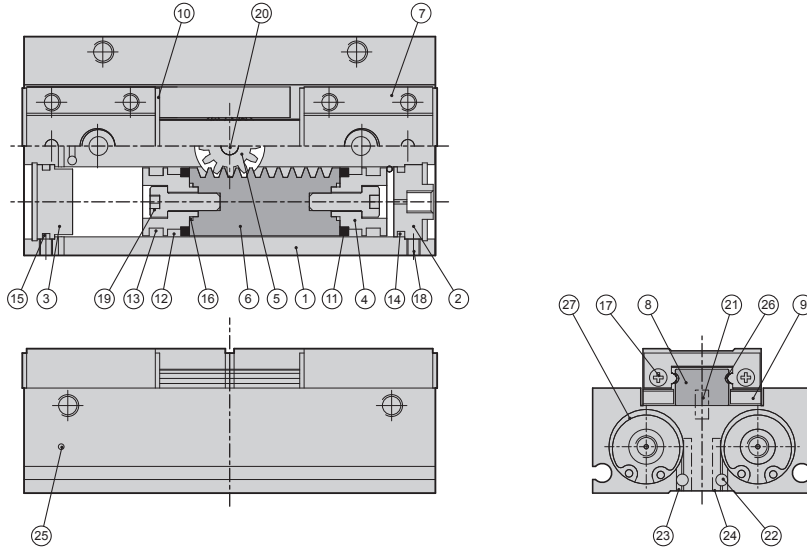

**HDS**  
Angular  
Gripper

**HDM**  
180° Angular  
Gripper

**HDP**  
Parallel  
Gripper

**HDK**  
Parallel  
Gripper

**HDF**  
Parallel  
Gripper

**HDZ**  
Parallel  
Gripper

**HDZL**  
Parallel  
Gripper

**HDW**  
Parallel  
Gripper

**HDL**  
Gripper

**HDT**  
Gripper

**HDR**  
Three  
Finger  
Gripper

### Components and Material list

No.	Item	Material	No.	Item	Material
01	Body	Aluminum alloy	15	End cover O-ring	NBR
02	Front cover	Aluminum alloy	16	Piston O-Ring	NBR
03	End cover	Aluminum alloy	17	Screw	Alloy steel
04	Piston	Aluminum alloy	18	Screw	Alloy steel
05	Gear rod	Middle carbon	19	Piston screw	Alloy steel
06	Gear rack	Stainless steel	20	Gear pin	Bearing steel
07	Slide table	Stainless steel	21	Slide rail pin	Bearing steel
08	Slide rail	Stainless steel	22	Steel ball	Stainless steel
09	Slide table stir slice	Stainless steel	23	Steel ball	Stainless steel
10	Ball stopper	Stainless steel	24	Steel ball	Stainless steel
11	Magnet	REM	25	Steel ball	Stainless steel
12	Wear ring	Graphite and fiber	26	Steel ball	Stainless steel
13	Piston packing	NBR	27	Snap ring	Spring steel
14	O-Ring	NBR			

### Packing and O-Ring

Item	Piston packing	Front cover O-Ring	End cover O-Ring	Piston O-Ring
Bore size mm / Number	4	2	2	4
<b>HDF - 08</b>	MYA - 5	Ø 6 x Ø 1	Ø 6 x Ø 1	—
<b>HDF - 12</b>	DYP - 12	Ø 10 x Ø 1	Ø 10 x Ø 1	Ø 4 x Ø 1
<b>HDF - 16</b>	DYP - 16	Ø 13.5 x Ø 1.5	Ø 14.5 x Ø 1.5	Ø 7.4 x Ø 1.2
<b>HDF - 20</b>	DYP - 20	Ø 17.5 x Ø 1.5	Ø 17.5 x Ø 1.5	Ø 5.8 x Ø 1.9

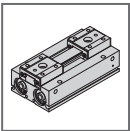

# HDF series - PARALLEL GRIPPER

(Thin type)

External dimension



CHELIC PNEUMATIC

## ► HDF - 8

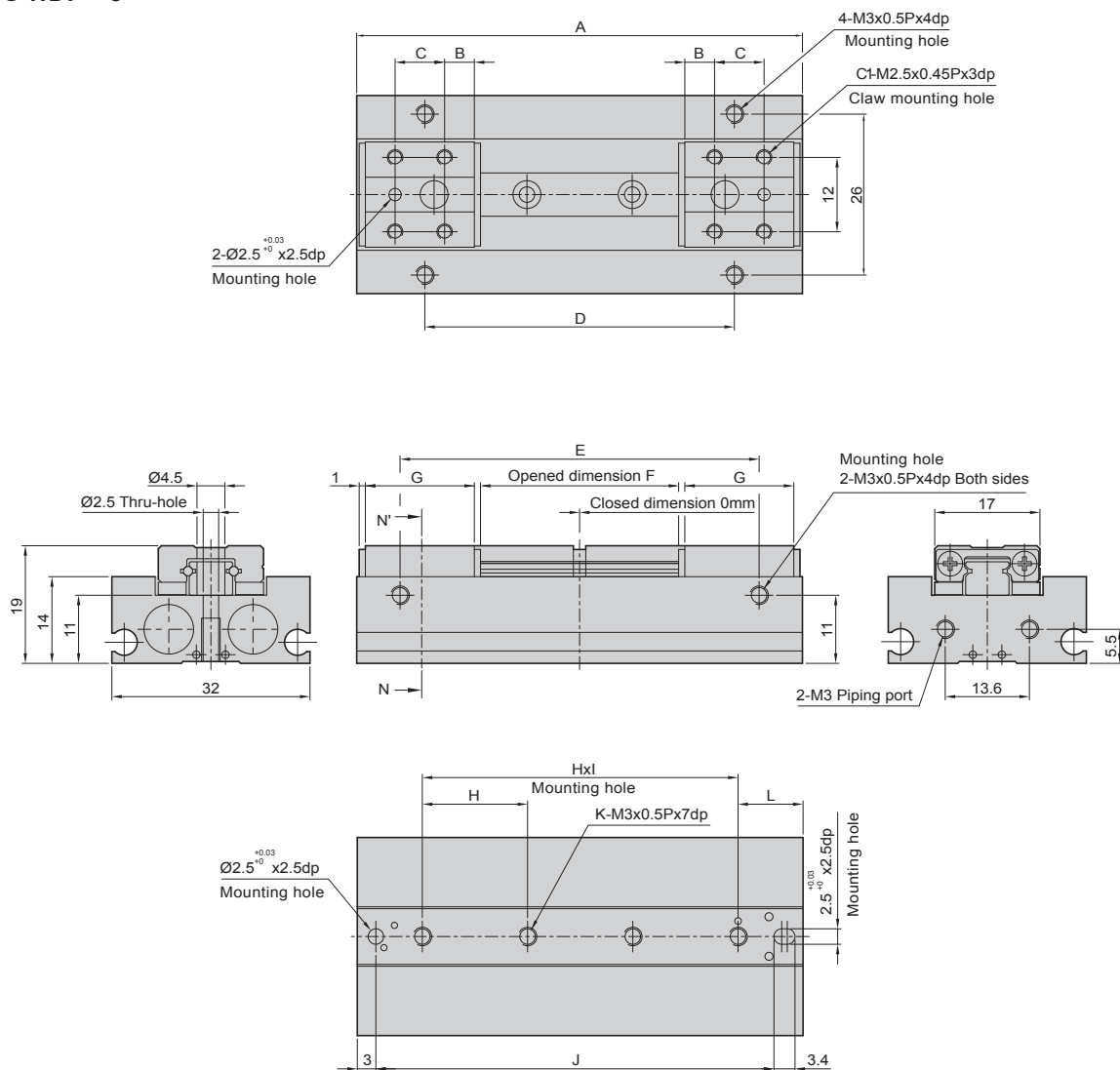

Code	A	B	C	C1	D	E	F	G	H	I	J	K	L
HDF8 x 8st	36	5.8	-	4	14	22	8	11.6	16	1	28.3	2	10
HDF8 x 16st	48	6.8	-	4	26	34	16	13.6	28	1	40.3	2	10
HDF8 x 32st	72	4.8	8	8	50	58	32	17.6	17	3	64.3	4	10.5

## ► Weight

Item	HDF 08x08	HDF 08x16	HDF 08x32
Weight	65g	85g	120g

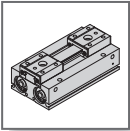

# HDF series - PARALLEL GRIPPER

External dimension

(Thin type)

CHELIC PNEUMATIC

## ● HDF - 12

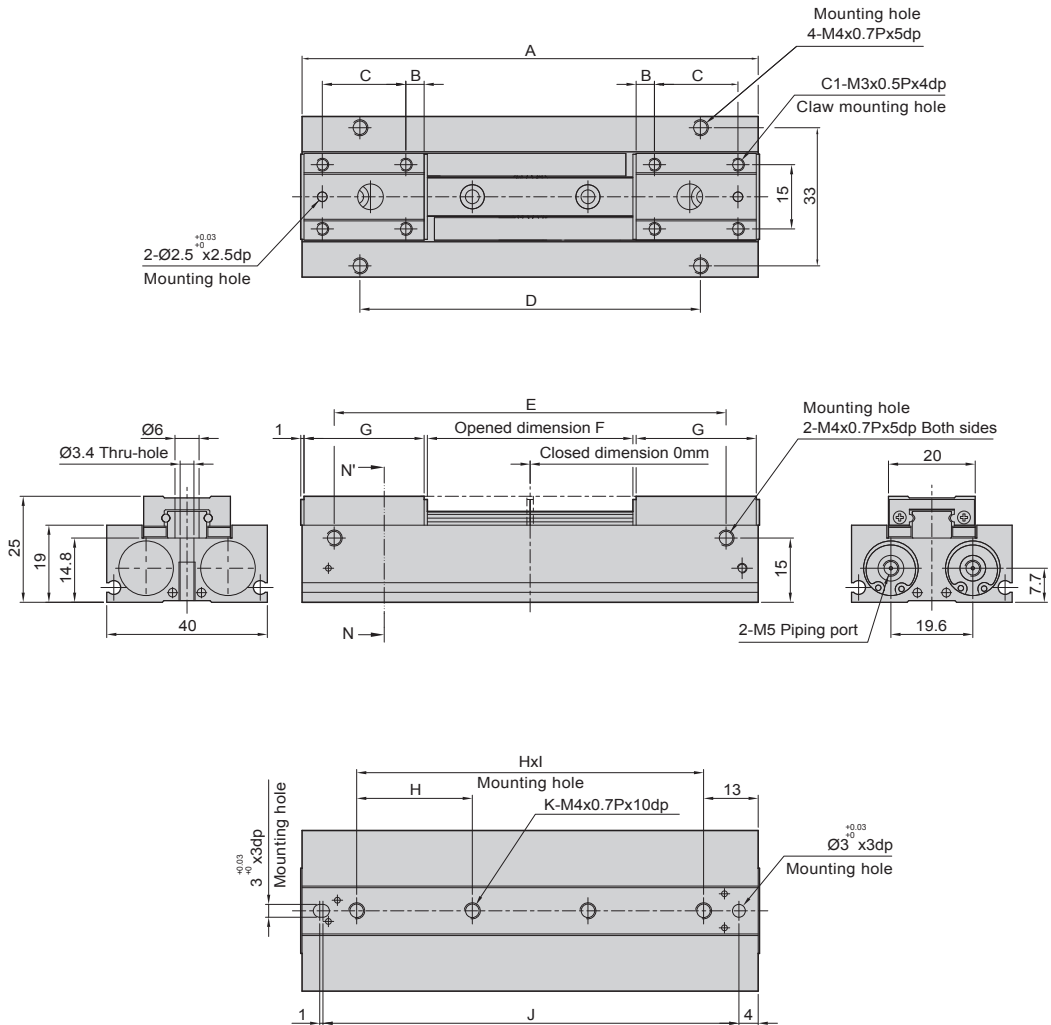

Code	A	B	C	C1	D	E	F	G	H	I	J	K
HDF-12X12st	52	9	-	4	28	38	12	18	26	1	43.5	2
HDF-12X24st	68	4.5	12	8	44	54	24	21	42	1	59.5	2
HDF-12X48st	104	4.5	18	8	80	90	48	27	26	3	95.5	4

## ● Weight

Item	HDF 12x12	HDF 12x24	HDF 12x48
Weight	155g	190g	275g

**HDS**  
Angular  
Gripper

**HDM**  
180°Angular  
Gripper

**HDP**  
Parallel  
Gripper

**HDK**  
Parallel  
Gripper

**HDF**  
Parallel  
Gripper

**HDZ**  
Parallel  
Gripper

**HDZL**  
Parallel  
Gripper

**HDW**  
Parallel  
Gripper

**HDL**  
Gripper

**HDT**  
Gripper

**HDR**  
Three  
Finger  
Gripper

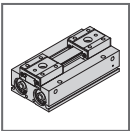

# HDF series - PARALLEL GRIPPER

External dimension

(Thin type)

CHELIC PNEUMATIC

## ► HDF - 16

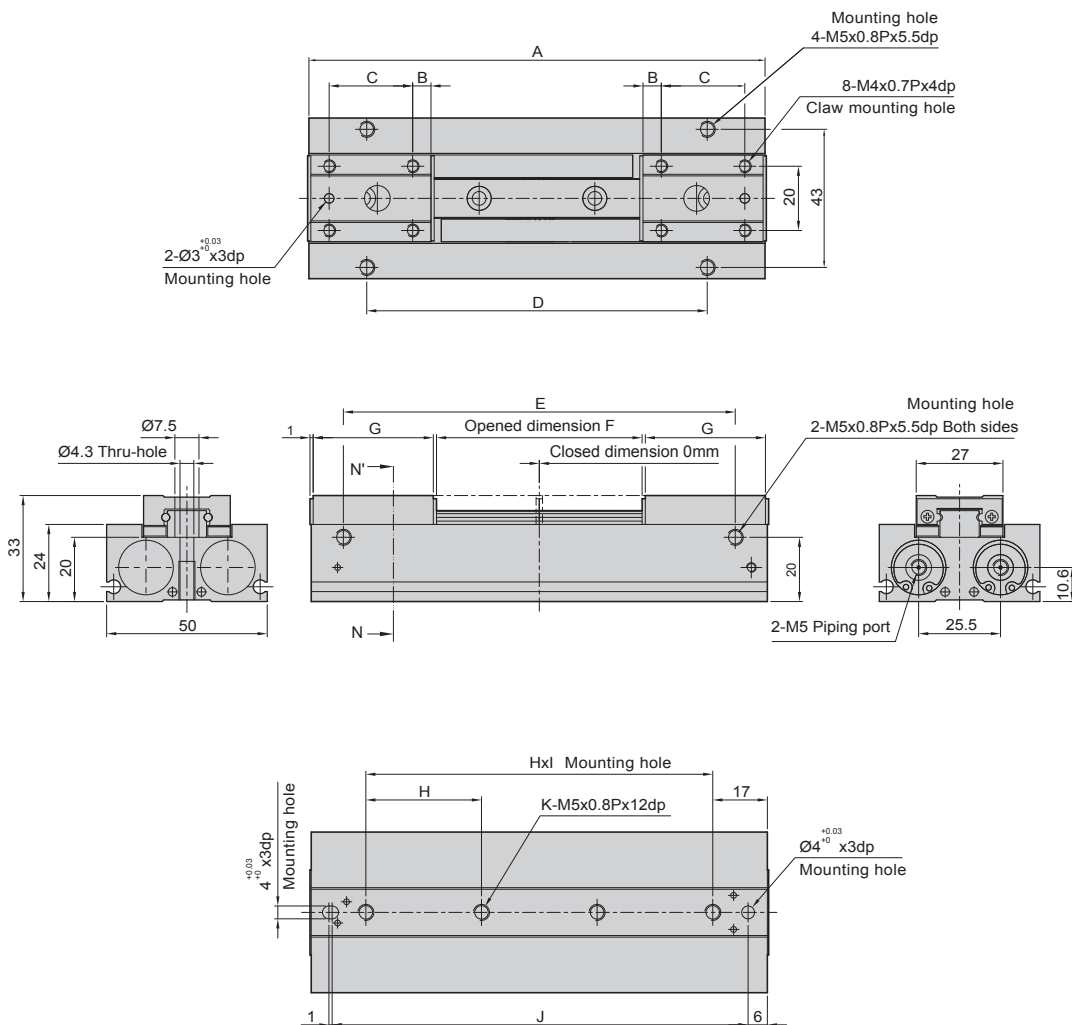

Dimension Model	Code	A	B	C	D	E	F	G	H	I	J	K
	HDF-16X16st	72	5.2	15	36	52	16	25.4	38	1	59.5	2
HDF-16X32st	94	5.7	18	58	74	32	29.4	60	1	81.5	2	
HDF-16X64st	142	5.7	26	106	122	64	37.4	36	3	129.5	4	

## ► Weight

Item	HDF 16x16	HDF 16x32	HDF 16x64
Weight	350g	445g	650g



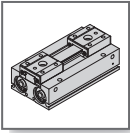

# HDF series - PARALLEL GRIPPER

External dimension

(Thin type)

CHELIC PNEUMATIC

## ► HDF - 20

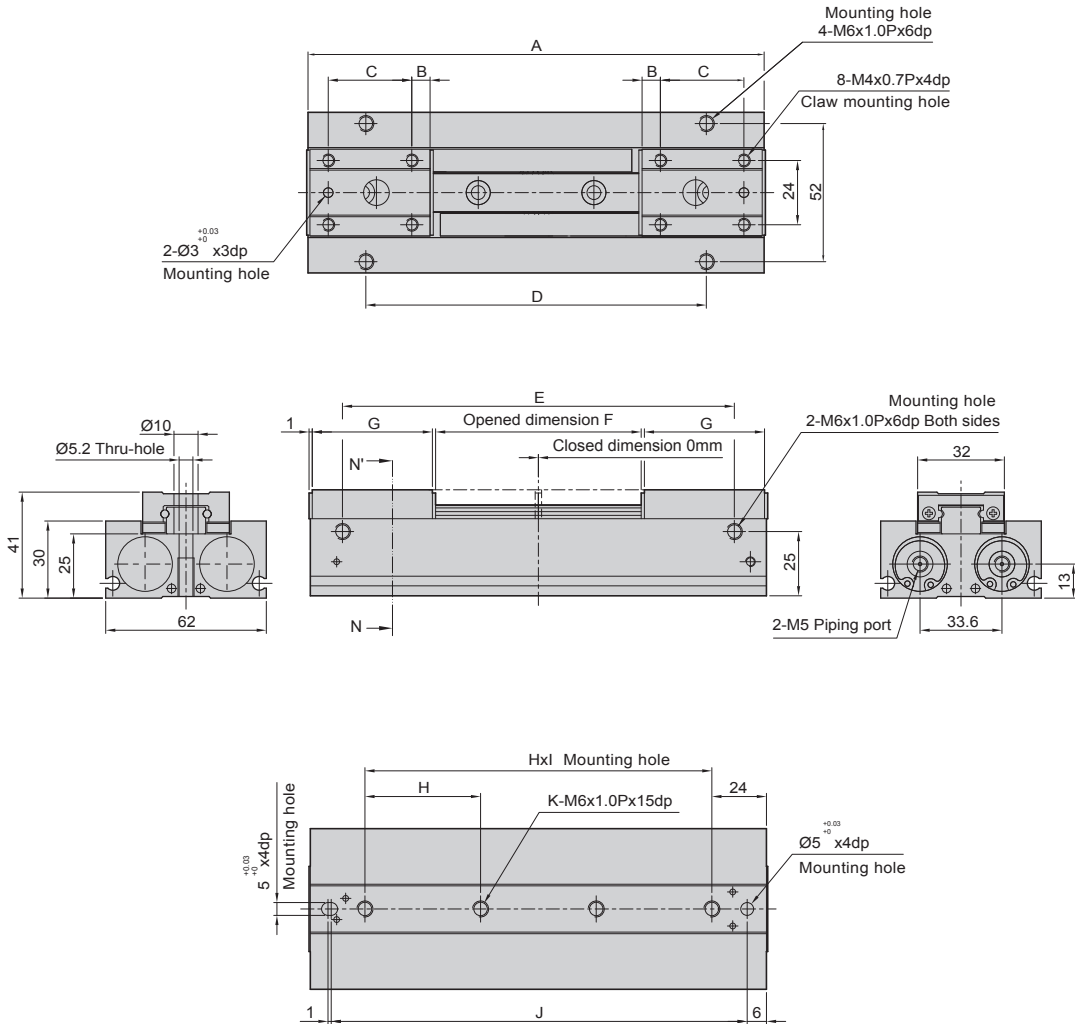

Code Dimension Model	A	B	C	D	E	F	G	H	I	J	K
HDF-20X20st	86	7.7	16	40	56	20	31.4	38	1	73.5	2
HDF-20X40st	114	8.2	20	68	84	40	36.4	66	1	101.5	2
HDF-20X80st	174	8.2	30	128	144	80	46.4	42	3	161.5	4

## ► Weight

Item	HDF 20x20	HDF 20x40	HDF 20x80
Weight	645g	850g	1225g

**HDS**  
Angular  
Gripper

**HDM**  
180° Angular  
Gripper

**HDP**  
Parallel  
Gripper

**HDK**  
Parallel  
Gripper

**HDF**  
Parallel  
Gripper

**HDZ**  
Parallel  
Gripper

**HDZL**  
Parallel  
Gripper

**HDW**  
Parallel  
Gripper

**HDL**  
Gripper

**HDT**  
Gripper

**HDR**  
Three  
Finger  
Gripper

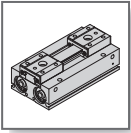

# HDF series - PARALLEL GRIPPER

Sensing setting and Sensing installation

(Thin type)

CHELIC PNEUMATIC

## ▶ Sensing setting and Installation

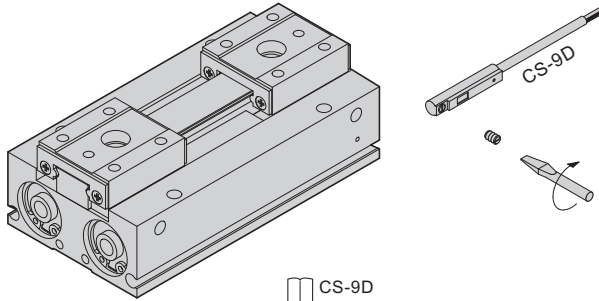

CS-9D  
( Please refer to P.22-1.15 Sensor switch standard )

## ▶ Sensing range

Sensor switch is fixed on the cylinder body.  
The magnetic piston head will activate the sensor switch when it enters the operating range. It has 0.5mm differential.

## ▶ Operating range

When piston head moves the switch setting and adjustment will be based on the responding range generated by the magnetic field and the switch.  
(Please refer to the below table)

Unit : mm

Model	CS-9D(B/H)	
Bore size	Operating range (F)	Response differential(R)
8	7	1
12	8	1
16	10	1.2
20	11	1.2

New

## ▶ Sensor switch setting and Operating range

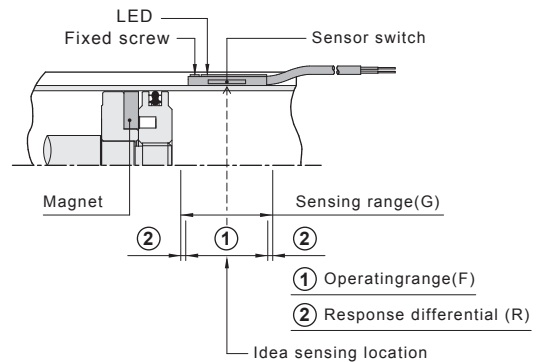

## ▶ Connection type

### CS-9D

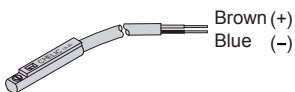

Voltage : DC 5 ~ 120V  
AC 5 ~ 120V

### CS-9B

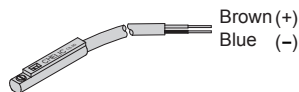

Voltage : DC 5 ~ 120V  
AC 5 ~ 120V

### CS-9H

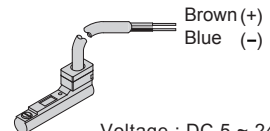

Voltage : DC 5 ~ 240V  
AC 5 ~ 240V