

SPECIFICATIONS SPMB 18B-R / 37B-R / 47B-R / 59B-R

| | |
|---|---|
| CAPACITIES: | 82, 159, 220, and 292 GPH. |
| PRESSURE: | Maximum operating pressure to 80 PSI or 200' of head. |
| MOTORS: | All motors are 60 HERTZ, 1725 RPM, continuous duty. SPLIT PHASE, 115 OR 230 VOLT operation 1/2 HP: Capacitor start / induction run, TEFC, DUAL 115/230 VOLT Motors are clockwise as viewed from motor shaft end. 50 HERTZ and/or 3 PHASE motors are available upon request. |
| PUMPS: | 18B-R, 37B-R, 47B-R, 59B-R |
| PORTING: | 18B, 37B, 47B 1/2" NPTF side inlet and outlet 59B 3/4" NPTF side inlet and outlet |
| SEAL: | All models - Double lip type. VITON |
| MOUNTING: | All models - Four bolt foot mount. |
| FILTER: | Use of external line filter recommended. |
| VALVES: | External pressure regulating or relief valve recommended. |
| GAUGE: | 2 1/2" DIA., Calibrated from 30" of HG vacuum to 100 PSI. |
| INLET VACUUM: | All units - 15" HG <u>maximum</u> . |
| NATIONAL FIRE PROTECTION ASSOCIATION COMPLIANCE REQUIRES FUEL INLET PRESSURE NOT TO EXCEED 3 PSIG. | |
| CONTROLS: | Duplex automatic with lead-lag switch, alarm, and push button test switch. Duplex manual with selector switch only. Additional controls are available. Contact the factory. |

SPMB Series Single and Duplex Supply Units

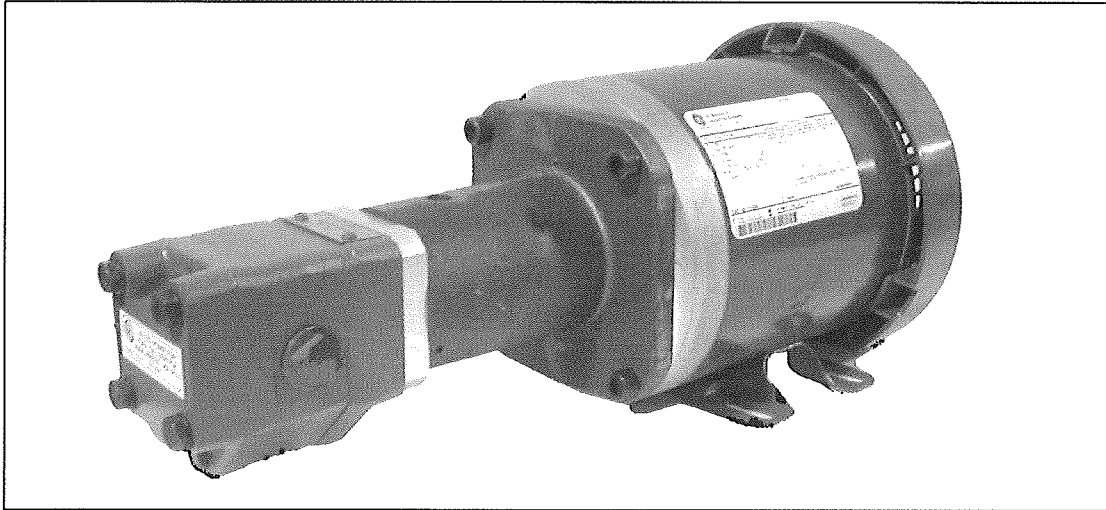

B series transfer pumps are designed to provide efficient pumping of #1 to #6 fuel oils, in capacities from 80 to 290 gallons per hour, at pressures up to 500 PSI (except #1 oil). With high-density gray iron body construction, heat-treated alloy steel gears and shafts, and special antifriction bearings. B series transfer pumps offer superior durability and

high mechanical efficiency. Double lip Viton seals, are standard. These pumps are also available in pump and motor packages. Available in 115/230 volt single phase or 230/460 volt three phase, simplex, duplex automatic and duplex manual configurations. All B series pumps are UL approved.

SPMB Pump Selection Table

| Selection Table | | SPMB Series Supply Pumps | | | | |
|------------------------------|--------------|----------------------------|-----------------------------|----------|------------------------|--------------------|
| Models and Design Data Table | | | | | | |
| Pump Head | Type | Required Motor HP @ 25 psi | Required Motor HP @ 100 psi | Max Head | Valve Adjustment Range | Max Flow @ 100 psi |
| Model No. | | | | | | |
| 18BR | Single Stage | .25 | .25 | 200' | No Adjustment | 150 |
| 37BR | Single Stage | .25 | .25 | 200' | No Adjustment | 160 |
| 47BR | Single Stage | .25 | .50 | 200' | No Adjustment | 220 |
| 59BR | Single Stage | .25 | .50 | 200' | No Adjustment | 290 |

External Relief or Regulating Valve Required. The RV3003 is mounted to the discharge manifold on the DA package

Supply Pump and Motor Code Breakdown

Examples: SPM-50AT2R213... SPMB-50AT59BR... SPMV-100BT086K-DA... SPMV-50BT086K-DA-PLC

| Basic Prefix | Pump Head | Dash | Motor HP | Motor Phase | Motor Enclosure | Webster | Dash | No Letter or |
|---------------------|--------------------|------|------------|--------------|--------------------|------------|------|-------------------------|
| Supply Pump & Motor | Series | | .25=1/4 hp | Voltage | TEFC, OPDP | Pump Head | | Blank = Single |
| | No Letter-Standard | | 500=5 hp | A=1 Phase | E- Explosion Proof | P/N Prefix | | DA = Duplex Automatic |
| | | | | B=3 Phase | | | | DM = Duplex Manual |
| | | | | X=Special | | | | DA-PLC |
| | | | | 50 or 60 cy. | | | | PLC Control Panel |
| SPM | B-V-No Letter | | .25 - 500 | A, B or X | T, O or E | Pump # | | Blank, DA, DA-PLC or DM |

SPMB Series Single and Duplex Supply Units

DIMENSIONS

| HP | Motor NEMA | | A | B | C |
|------|---------------|--------------------|-------|-------|-------|
| | Fame Size | Type (Standard) | | | |
| .50 | 56C | TEFC | 9.00 | 8.25 | 9.20 |
| .75 | 56C | TEFC | 9.00 | 8.25 | 9.20 |
| 1.00 | 56C | TEFC | 9.00 | 8.25 | 10.20 |
| 1.50 | 56C | TEFC | 9.00 | 8.25 | 11.20 |
| 2.00 | 56C | TEFC | 9.00 | 8.25 | 11.20 |
| 3.00 | 182TC | OPDP | 9.63 | 11.05 | 11.00 |
| 5.00 | 184TC | OPDP | 9.63 | 11.05 | 12.40 |
| 7.50 | 213TC | OPDP | 11.63 | 13.00 | 13.90 |

| Pump Model | E | D |
|---------------|------|---------------|
| 18BR | 3.36 | (.50HP) 17.06 |
| 37BR | 3.71 | (.75HP) 17.41 |
| 47BR | 4.05 | (.75HP) 17.75 |
| 59BR | 4.40 | (.75HP) 18.10 |

SPMB SINGLE SUPPLY UNIT

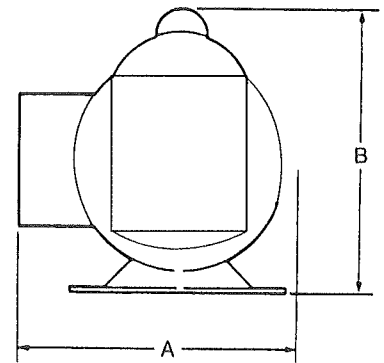
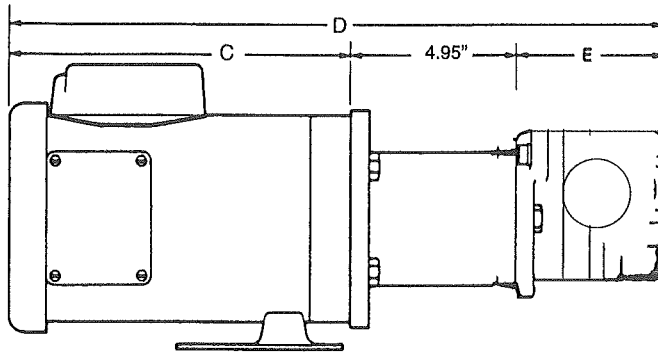

SPMB DUPLEX SUPPLY UNIT

(Dimensions are for
3 Phase Duplex
Automatic
Consult Factory
for Single Phase
Dimensions)

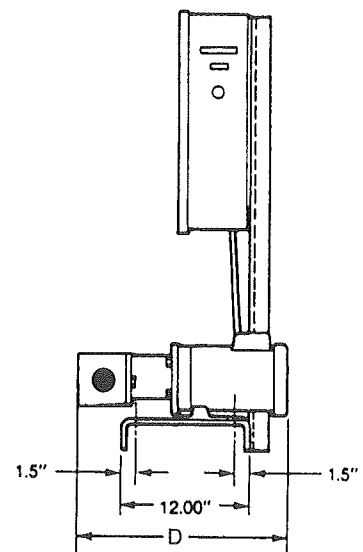
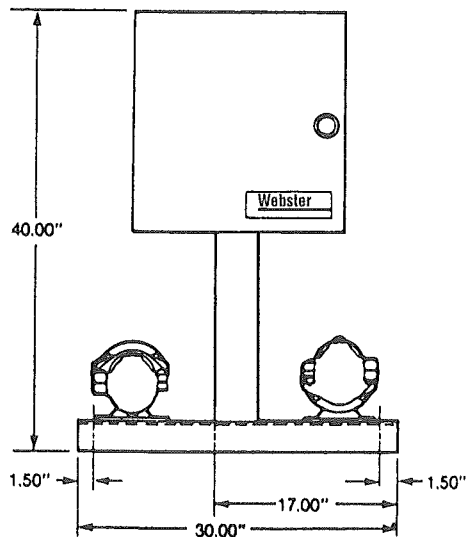

SPMB Ordering Code

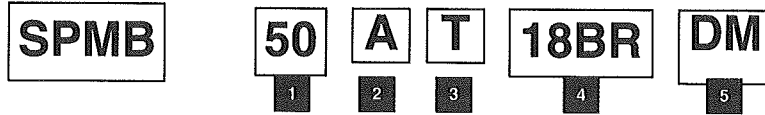

MOTOR HORSEPOWER (1725 RPM STANDARD)

| 1 | No. | Description |
|---|------|-------------|
| | * 25 | .25 HP |
| | 33 | .33 HP |
| | 50 | .50 HP |
| | 75 | .75 HP |
| | 100 | 1.0 HP |
| | 150 | 1.5 HP |
| | 200 | 2.0 HP |
| | 300 | 3.0 HP |

* = only available in 115V or 230V single phase

MOTOR PHASE

| 2 | Code | Description |
|---|------|--|
| | A | Single Phase / 60 cycle / 115/208/230 VAC |
| | B | Three Phase / 60 cycle / 208 / 230 / 460 VAC |
| | X | Consult factory for other types |

MOTOR ENCLOSURE

| 3 | Code | Description |
|---|------|---------------------|
| | T | TEFC Std/ thru 2 HP |
| | O | OPDP Std. over 2 HP |

When sizing SPMB units, remember that the pressures indicated are at the pump outlet.

All pumps relying on atmospheric pressure to push the fuel oil into them are subject to cavitation. As fuel viscosity (thickness) increases, the tendency for cavitation becomes greater. Therefore, it is best to mount the pump at the base of the tank and to use the largest diameter, shortest length, and straightest inlet possible.

MOTOR HORSEPOWER (1725 RPM STANDARD)

| 4 | Pump Model | Maximum gph Nominal | Under pressure, read horsepower required at 1750 RPM | | | |
|---|------------|---------------------|--|---------|---------|---------|
| | | | 25 psi | 100 psi | 200 psi | 300 psi |
| | 18BR | 82 | .25 | .25 | .25 | .33 |
| | 37BR | 159 | .25 | .25 | .50 | .75 |
| | 47BR | 220 | .25 | .50 | .75 | 1.00 |
| | 59BR | 292 | .25 | .50 | .75 | 1.50 |

SPMB Duplex Ordering Code

When ordering SPMB Duplex models add suffix:

"DM," for manual control models, or "DA," for automatic control models.

Example: SPMB-50AT/18BR-DA

| 5 | Code | Duplex Units |
|---|--------|--|
| | DM | Duplex with manual controls |
| | DA | Duplex with automatic controls |
| | DA-PLC | Duplex with PLC OIL Management Control Panel |

A large diameter inlet pipe or hose necked-down at the pump is preferable to a longer length of similar diameter pipe because the fuel tends to adhere to the inside of the pipe.

When initially starting a unit, it is desirable and sometimes necessary to have a vent valve or plug on the pressure side of the pump to facilitate its priming.

The Duplex Automatic Pump and Motor PLC Based Oil Management Control Panel options are as follows.

- Microprocessor Base Programmable Logic Controller
- Remote Monitoring Capabilities via Ethernet and or Wireless Communication. Internet connection is needed to interface with the PLC panel in order to provide real time remote monitoring.
- Audio and Visual Alarm
- Duplex Automatic Panel with Automatic Switch Over
- High/Low Level and Leak Detection Interface with Alarm and Shut Down
- Automatic Alternation to allow for equal run time between pump sets every 14 days
- Pressure Transducer to detect pump failure and to allow back-up pump to energize
- 6" LED Touch Display Panel
- Vacuum and Pressure Monitoring
- Motor Starters with MCP's (Motor circuit protector)
- Quick Disconnect
- ETM Time Elapsed Recorders for Each Pump Set for Later Verification
- Event Summary
- NEMA 4/12 Enclosure
- Control System is equipped to monitor and control
 1. Hand-Off-Automatic Control
 2. Lead Pump Selection – Auto/Manual
 3. Pump Status – Off/Run/Standby
 4. Pressure and Vacuum Status - Normal/High/Low
 5. Main Tank/Day Tank Status – Normal/High/Low/Leak
- Controllers are field expandable using plug-in input modules to monitor up to 4 storage tanks and 12 discriminating leak sensors.
- Motor Failure Alarm
- Light to indicate normal power on, run, and off conditions
- Remote HMI Access for real time remote monitoring and control (APP Download Required)
- Advanced features of Touch Panel: Remote Access and Control feature. Send email with embedded PLC data, Send logged data to an external PC, Retrieve logged panel data remotely via the internet, Clear old logged data on a routing frequency. Unit can communicate with different brands of PLCs at the same time.

NOTE: Installer should be familiar with PLC based controls and remote wireless interface in order to enable all the features this panel can provide.

The Complete PLC Duplex Pump and Motor Assembly will also include...

- Flow rates available from 80 GPH up to 290 GPH
- Discharge pressures from 10-55 psig
- 1725 rpm Direct Drive Motors
- Two Pump and Motor assemblies
- One Compound Gauge on discharge block
- One Discharge connection
- One regulator/relief/back pressure valve combination on common discharge manifold
- Two Inlet Strainers
- Containment Basin (36" x 24") with drain plug, leak sensor and fork lift access
- Inlet Isolation Valves

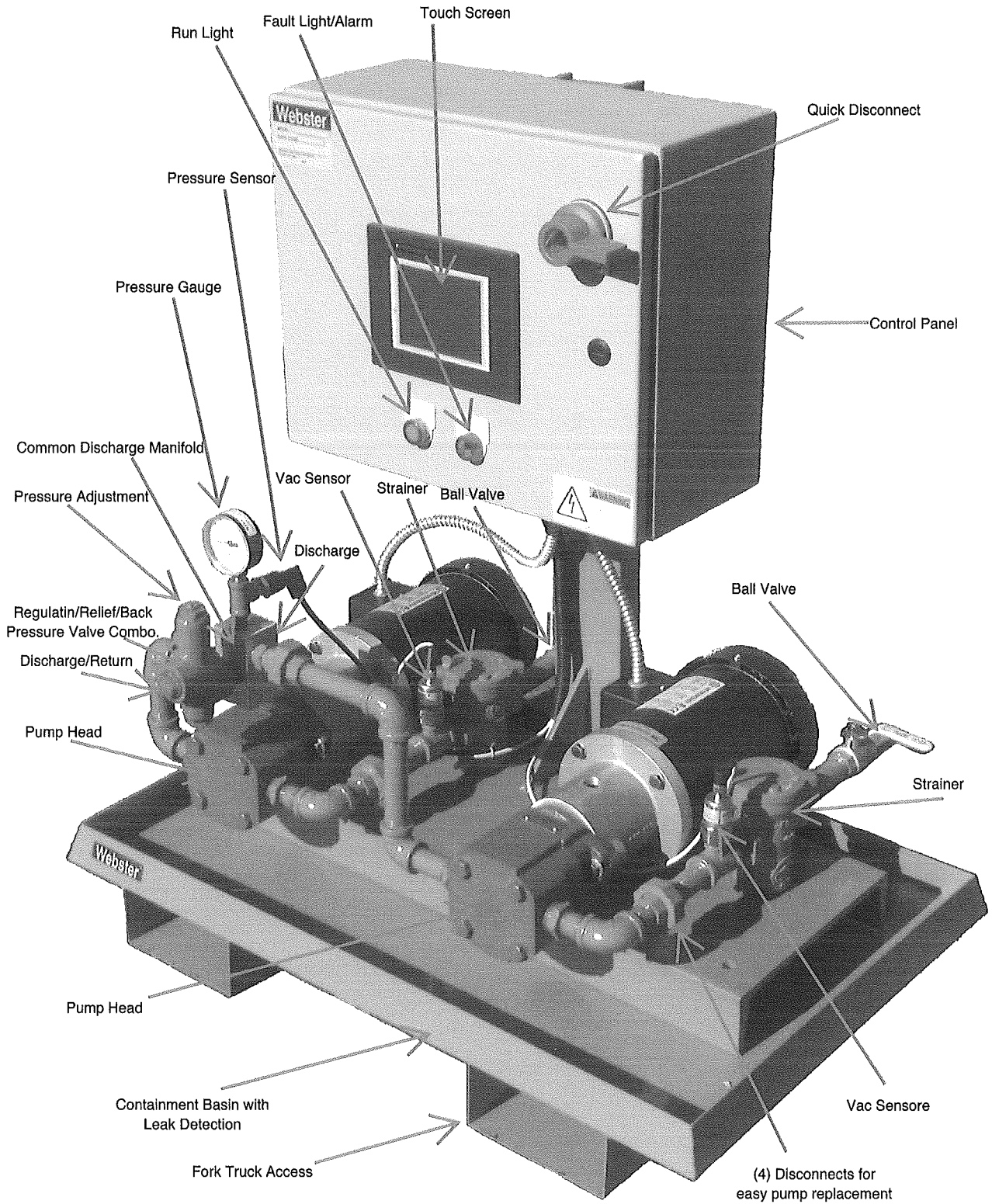

The above SPM pump set is sitting on a 36" x 24" containment basin. Dimensions may vary depending on model. Sensors are not included with our standard panel.