

SGDH-@, SGM@H-@

Sigma-II Series

The Ideal servo family for motion control. Fast Response, High Speed, and High Accuracy.

- Online autotuning with 10 levels of rigidity
- Peak torque 300% of nominal
- Automatic motor recognition
- Analogue control for speed and torque
- Pulse train control for positioning
- Optional Units for system flexibility and network connectivity
- Smooth operation
- Oscilloscope available via SigmaWin tool
- Windows based Configuration and commissioning software

Ratings

- 230VAC Single-phase 30 W to 1.5kW (4.77 Nm)
- 400VAC Three-phase 450 W to 15 kW (95.4 Nm)



System Configuration

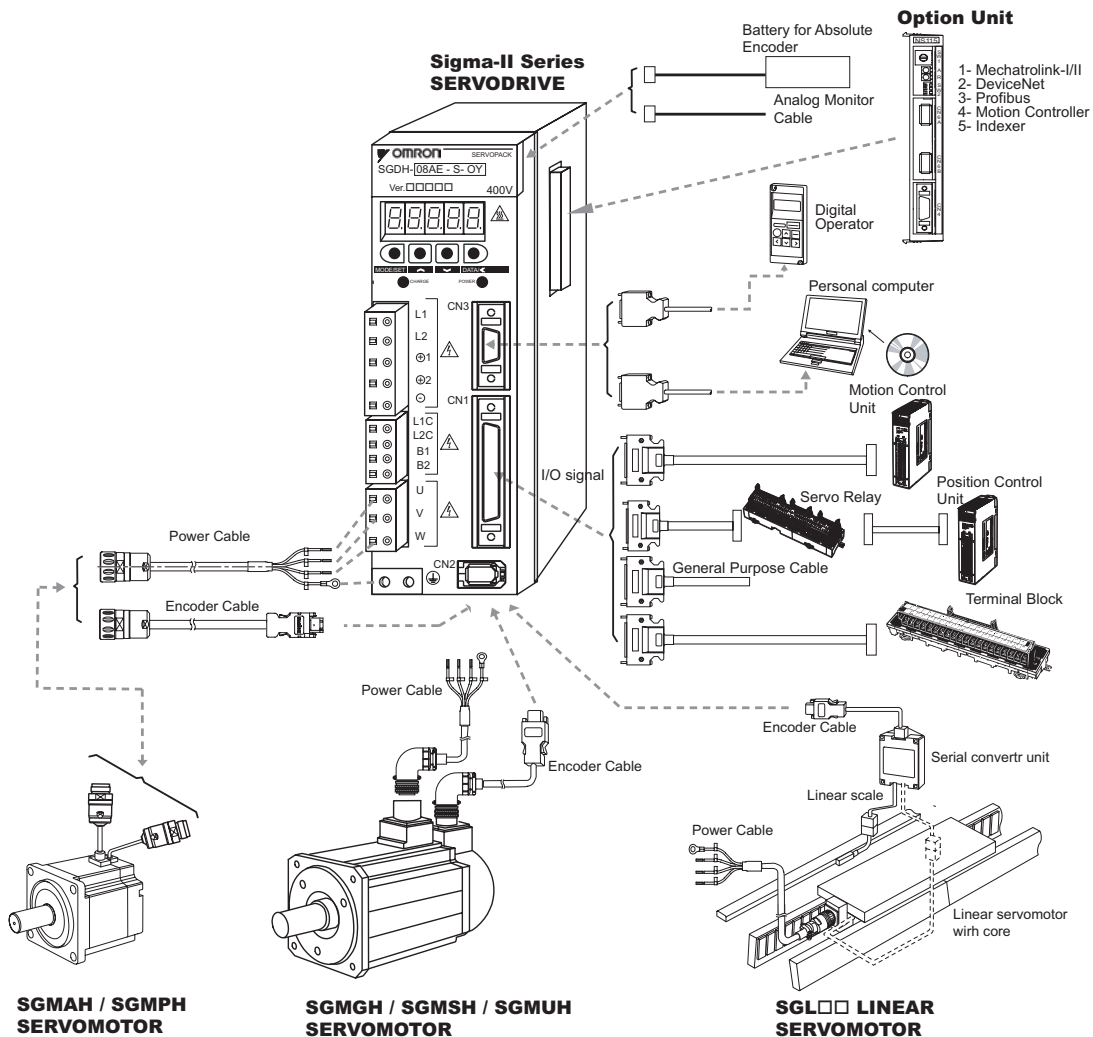

Servomotor / Servo Drive Combination

Σ-II



Servomotor				Servo Drive	
	Voltage	Rated Torque	Capacity	230 V (1-phase)	400 V (3-phase)
 SGMAH (3000 min ⁻¹)	230 V	0.0955 N.m	30 W	SGDH-A3AE-OY	-
		0.159 N.m	50 W	SGDH-A5AE-OY	-
		0.318 N.m	100 W	SGDH-01AE-OY	-
		0.637 N.m	200 W	SGDH-02AE-OY	-
		1.27 N.m	400 W	SGDH-04AE-OY	-
		2.39 N.m	750 W	SGDH-08AE-S-OY	-
	400 V	0.955 N.m	300 W	-	SGDH-05DE-OY
 SGMPH (3000 min ⁻¹)	230 V	0.318 N.m	100 W	SGDH-01AE-OY	-
		0.637 N.m	200 W	SGDH-02AE-OY	-
		1.27 N.m	400 W	SGDH-04AE-OY	-
		2.39 N.m	750 W	SGDH-08AE-S-OY	-
		4.77 N.m	1500 W	SGDH-15AE-S-OY	-
	400 V	0.637 N.m	200 W	-	SGDH-05DE-OY
		1.27 N.m	400 W	-	SGDH-05DE-OY
		2.39 N.m	750 W	-	SGDH-10DE-OY
 SGMGH (1500 min ⁻¹)	400 V	2.84 N.m	0.45 kW	-	SGDH-05DE-OY
		5.39 N.m	0.85 kW	-	SGDH-10DE-OY
		8.34 N.m	1.3 kW	-	SGDH-15DE-OY
		11.5 N.m	1.8 kW	-	SGDH-20DE-OY
		18.6 N.m	2.9 kW	-	SGDH-30DE-OY
		28.4 N.m	4.4 kW	-	SGDH-50DE-OY
		35.0 N.m	5.5 kW	-	SGDH-60DE-OY
		48.0 N.m	7.5 kW	-	SGDH-75DE-OY
		70.0 N.m	11 kW	-	SGDH-1A DE-OY
		95.4 N.m	15 kW	-	SGDH-1E DE-OY
 SGMSH (3000 min ⁻¹)	400 V	3.18 N.m	1.0 kW	-	SGDH-10DE-OY
		4.90 N.m	1.5 kW	-	SGDH-15DE-OY
		6.36 N.m	2.0 kW	-	SGDH-20DE-OY
		9.80 N.m	3.0 kW	-	SGDH-30DE-OY
		12.6 N.m	4.0 kW	-	SGDH-50DE-OY
		15.8 N.m	5.0 kW	-	SGDH-50DE-OY
 SGMUH (6000 min ⁻¹)	400 V	1.59 N.m	1.0 kW	-	SGDH-10DE-OY
		2.45 N.m	1.5 kW	-	SGDH-15DE-OY
		4.9 N.m	3.0 kW	-	SGDH-30DE-OY
		6.3 N.m	4.0 kW	-	SGDH-50DE-OY
 SGLGW Linear Motors	230 V	Refer to the Linear Motors chapter for details			
 SGLFW Linear Motors	230 V, 400 V	Refer to the Linear Motors chapter for details			
 SGLTW Linear Motors	400 V	Refer to the Linear Motors chapter for details			

Type Designation

Servomotor

SGMAH - 01 A 1 A 6 S D - OY

Sigma-II Servomotor Type

- SGMAH: Super High Power Rate Type
- SGMPH: Cube Type
- SGMGH: High-speed Feed Type
- SGMSH: Super High Power Rate Type
- SGMUH: High Speed Type

Connector Specifications

Blank	No option
D	Hypertac Connector (SGMAH,SGMPH)

Brake, Oil Seal Specifications

1	No Brake, No Oil/Dust Seal
S	Oil Seal
B	90V Brake
C	24V Brake
D	Oil Seal + 90VDC Brake
E	Oil Seal + 24VDC Brake
F	Dust Seal
G	Dust Seal + 90VDC Brake
H	Dust Seal + 24VDC Brake

Capacity (kW)

Code	SGMAH	SGMPH	SGMGH	SGMSH	SGMUH
	3000 min ⁻¹	3000 min ⁻¹	1500 min ⁻¹	3000 min ⁻¹	6000 min ⁻¹
A3	0.03				
A5	0.05				
01	0.1	0.1			
02	0.2	0.2			
03	0.3				
04	0.4	0.4			
05			0.45		
06					
07	0.65				
08	0.75	0.75			
09			0.85		
10				1.0	1.0
12					
13			1.3		
15		1.5		1.5	1.5
20			1.8	2.0	
22					
30			2.9	3.0	3.0
32					
40				4.0	4.0
44			4.4		
50				5.0	
55			5.5		
60					
75			7.5		
1A			11		
1E			15		

Shaft End Specifications

Code	Shaft End	Type				
		SGMAH	SGMPH	SGMGH	SGMSH	SGMUH
2	Straight, No key	<input type="radio"/>	<input type="radio"/>	<input type="radio"/>	<input type="radio"/>	<input type="radio"/>
4	Straight, Key	<input type="radio"/>	<input type="radio"/>	<input type="radio"/>	<input type="radio"/>	<input type="radio"/>
6	Straight, Key, Tapped	<input checked="" type="radio"/>	<input checked="" type="radio"/>	<input checked="" type="radio"/>	<input checked="" type="radio"/>	<input checked="" type="radio"/>
8	Straight, Tapped	<input type="radio"/>	<input type="radio"/>	<input type="radio"/>	<input type="radio"/>	<input type="radio"/>

: Standard : Option

Design Procedure:

- A: Standard
- E: SGMPH (IP67)
- F: SGMAH (prepared for oil seal mounting)

Serial Encoder Specifications

Code	Encoder	Type				
		SGMAH	SGMPH	SGMGH	SGMSH	SGMUH
1	16-bit Absolute	<input type="radio"/>	<input type="radio"/>	<input type="radio"/>	<input type="radio"/>	<input type="radio"/>
2	17-bit Absolute			<input type="radio"/>	<input type="radio"/>	
A	13-bit Incremental	<input checked="" type="radio"/>	<input checked="" type="radio"/>			
B	16-bit Incremental	<input type="radio"/>	<input type="radio"/>			
C	17-bit Incremental			<input checked="" type="radio"/>	<input checked="" type="radio"/>	<input checked="" type="radio"/>

: Standard : Option

Voltage

- A: 230 V
- D: 400 V

Servo Drive

SGDH - 04 A E - S - OY

Sigma-II Servo Drive

Capacity

A3	30 W	15	1.5 kW
A5	50 W	20	2.0 kW
01	100 W	30	3.0 kW
02	200 W	50	5.0 kW
04	400 W	60	6.0 kW
05	500 W	75	7.5 kW
08	750 W	1A	11 kW
10	1.0 kW	1E	15 kW

Phase

Blank	Three-phase (0.5 to 15kW) Single-phase (30 to 400W)
S	Single-phase (750W/1.5kW)

Model

- E: Speed, Torque, Position

Source Voltage

- A: 230V
- D: 400V

Servomotor Specifications

Type SGMAH, 230V/400V

Ratings and Specifications

Applied Voltage		230 V						400 V	
Servomotor Model SGMAH-@		A3A@	A5A@	01A@	02A@	04A@	08A@	03D@	07D@
Rated Output	W	30	50	100	200	400	750	300	650
Rated Torque	N·m	0.096	0.159	0.318	0.637	1.27	2.39	0.955	2.07
Instantaneous Peak Torque	N·m	0.286	0.477	0.955	1.91	3.82	7.16	3.82	7.16
Rated Current	A (rms)	0.44	0.64	0.91	2.1	2.8	4.4	1.3	2.2
Instantaneous Max. Current	A (rms)	1.3	2.0	2.8	6.5	8.5	13.4	5.1	7.7
Rated Speed	min ⁻¹	3000							
Max. Speed	min ⁻¹	5000							
Torque Constant	N·m/A (rms)	0.238	0.268	0.378	0.327	0.498	0.590	0.837	1.02
Rotor Moment of Inertia (JM)	kg·m ² ×10 ⁻⁴	0.017	0.022	0.036	0.106	0.173	0.672	0.173	0.672
Allowable Load Moment of Inertia (JL)	Multiple of (JM)	30				20			
Rated Power Rate	kW/s	5.49	11.5	27.8	38.2	93.7	84.8	52.9	63.8
Rated Angular Acceleration	rad/s ²	57500	72300	87400	60100	73600	35500	55300	30800
Applicable Encoder	Standard	Incremental Encoder (13 bits: 2048P/R)							
	Option	Incremental/Absolute Encoder (16 bits: 16384P/R)							
Holding Brake Moment of Inertia J	kg·m ² ×10 ⁻⁴	0.0085			0.058		0.14	0.058	0.14
Basic Specifications	Time Rating	Continuous							
	Insulation Class	Class B							
	Ambient Temperature	0 to +40° C							
	Ambient Humidity	20 to 80% (non-condensing)							
	Vibration Class	15µm or below							
	Enclosure	Totally-enclosed, self-cooled, IP55 (excluding shaft opening)							
	Vibration Resistance	Vibration acceleration 49m/s ²							
	Mounting	Flange-mounted							

Torque-Speed Characteristics

(A : Continuous Duty Zone B : Intermittent Duty Zone)

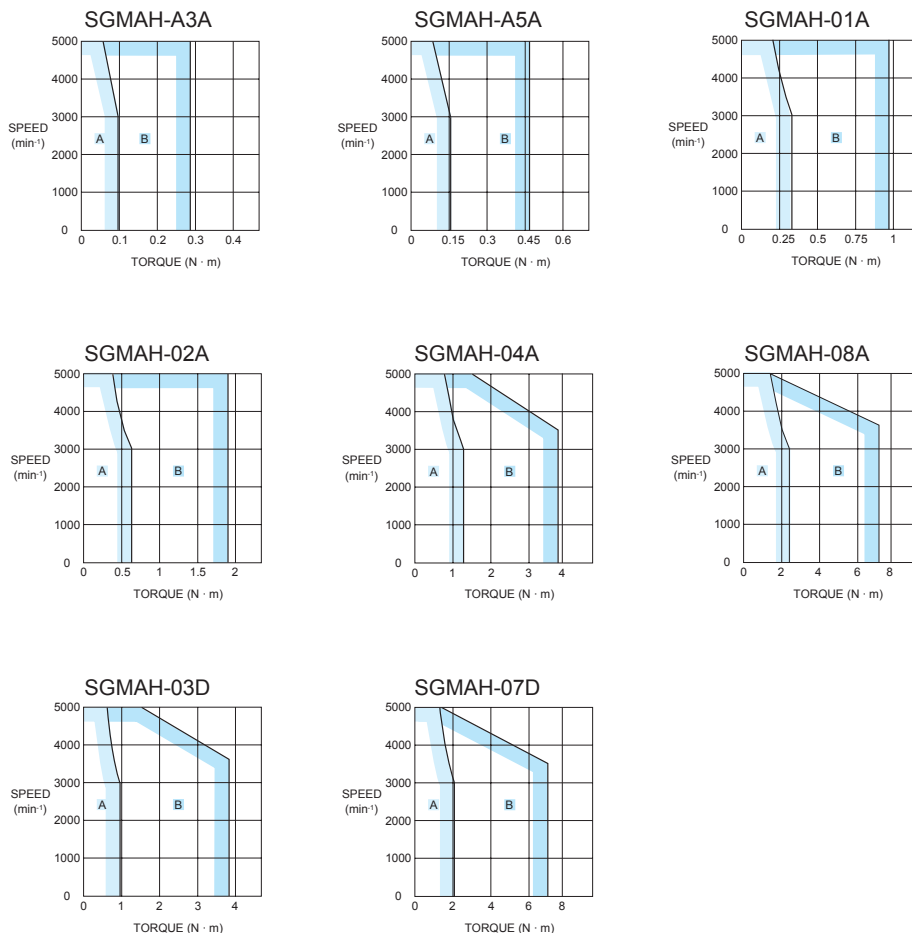

Type SGMPH, 230V/400V

Ratings and Specifications

Applied Voltage		230 V					400 V				
Servomotor Model SGMPH-@		01A@	02A@	04A@	08A@	15A@	02D@	04D@	08D@	15D@	
Rated Output	W	100	200	400	750	1500	200	400	750	1500	
Rated Torque	N·m	0.318	0.637	1.27	2.39	4.77	0.637	1.27	2.39	4.77	
Instantaneous Peak Torque	N·m	0.955	1.91	3.82	7.16	14.3	1.91	3.82	7.16	14.3	
Rated Current	A (rms)	0.89	2.0	2.6	4.1	7.5	1.4	1.4	2.6	4.5	
Instantaneous Max. Current	A (rms)	2.8	6.0	8.0	13.9	23.0	4.6	4.4	7.8	13.7	
Rated Speed	min ⁻¹	3000									
Max. Speed	min ⁻¹	5000									
Torque Constant	N·m/A (rms)	0.392	0.349	0.535	0.641	0.687	0.481	0.963	0.994	1.14	
Rotor Moment of Inertia (JM)	kg·m ² ×10 ⁻⁴	0.0491	0.193	0.331	2.10	4.02	0.193	0.331	2.10	4.02	
Allowable Load Moment of Inertia (JL)	Multiple of (JM)	25	15	7	5		15	7	5		
Rated Power Rate	kW/s	20.6	21.0	49.0	27.1	56.7	21.0	49.0	27.1	56.7	
Rated Angular Acceleration	rad/s ²	64800	33000	38500	11400	11900	33000	38500	11400	11900	
Applicable Encoder	Standard	Incremental Encoder (13 bits: 2048P/R)									
	Option	Incremental/Absolute Encoder (16 bits: 16384P/R)									
Holding Brake Moment of Inertia J	kg·m ² ×10 ⁻⁴	0.029	0.109	0.875			0.109	0.875			
Basic Specifications	Time Rating	Continuous									
	Insulation Class	Class B									
	Ambient Temperature	0 to +40° C									
	Ambient Humidity	20 to 80% (non-condensing)									
	Vibration Class	15µm or below									
	Enclosure	Totally-enclosed, self-cooled, IP55 (excluding shaft opening)									
	Vibration Resistance	Vibration acceleration 49m/s ²									
	Mounting	Flange-mounted									

Torque-Speed Charecteristics

(A : Continuous Duty Zone B : Intermittent Duty Zone)

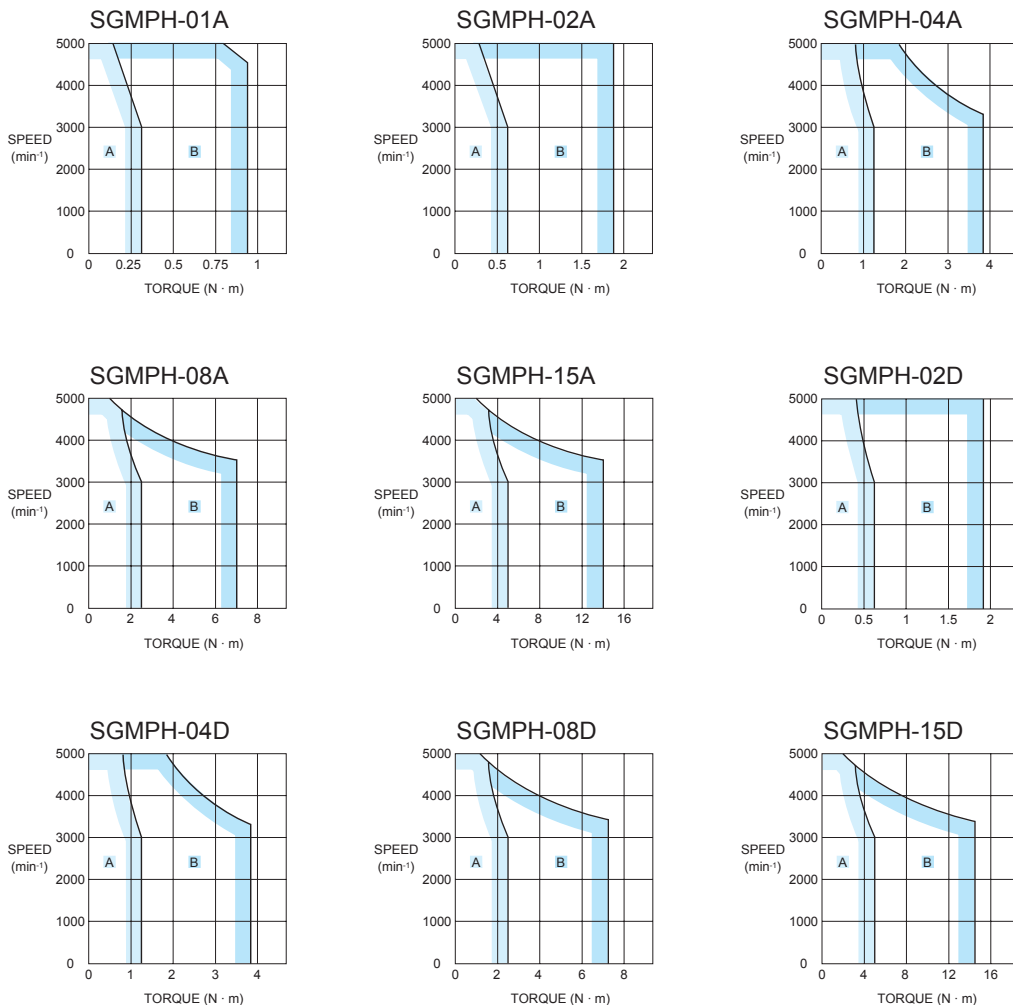

Type SGMGH, 400V

Ratings and Specifications

Applied Voltage		400 V									
Servomotor Model SGMGH-@		05D@	09D@	13D@	20D@	30D@	44D@	55D@	75D@	1AD@	1ED@
Rated Output	kW	0.45	0.85	1.3	1.8	2.9	4.4	5.5	7.5	11	15
Rated Torque	N·m	2.84	5.39	8.34	11.5	18.6	28.4	35.0	48.0	70.0	95.4
Instantaneous Peak Torque	N·m	8.92	13.8	23.3	28.7	45.1	71.1	90.7	123	175	221
Rated Current	A (rms)	1.9	3.5	5.4	8.4	11.9	16.5	20.8	25.4	28.1	37.2
Instantaneous Max. Current	A (rms)	5.5	8.5	14	20	28	40.5	55	65	70	85
Rated Speed	min ⁻¹	1500									
Max. Speed	min ⁻¹	3000								2000	
Torque Constant	N·m/A (rms)	1.64	1.65	1.68	1.46	1.66	1.82	1.74	2.0	2.56	2.64
Rotor Moment of Inertia (JM)	kg·m ² ×10 ⁻⁴	7.24	13.9	20.5	31.7	46.0	67.5	89.0	125	281	315
Allowable Load Moment of Inertia (JL)	Multiple of (JM)	5									
Rated Power Rate	kW/s	11.2	20.9	33.8	41.5	75.3	120	137	184	174	289
Rated Angular Acceleration	rad/s ²	3930	3880	4060	3620	4050	4210	3930	3850	2490	3030
Applicable Encoder	Standard	Incremental Encoder (17 bits: 16384P/R)									
	Option	Absolute Encoder (17 bits: 16384P/R)									
Holding Brake Moment of Inertia J	kg·m ² ×10 ⁻⁴	2.10				8.50				18.8	37.5
Basic Specifications	Time Rating	Continuous									
	Insulation Class	Class F									
	Ambient Temperature	0 to +40° C									
	Ambient Humidity	20 to 80% (non-condensing)									
	Vibration Class	15µm or below									
	Enclosure	Totally-enclosed, self-cooled, IP67 (excluding shaft opening)									
	Vibration Resistance	Vibration acceleration 24.5m/s ²									
	Mounting	Flange-mounted									

Torque-Speed Characteristics

(A : Continuous Duty Zone B : Intermittent Duty Zone)

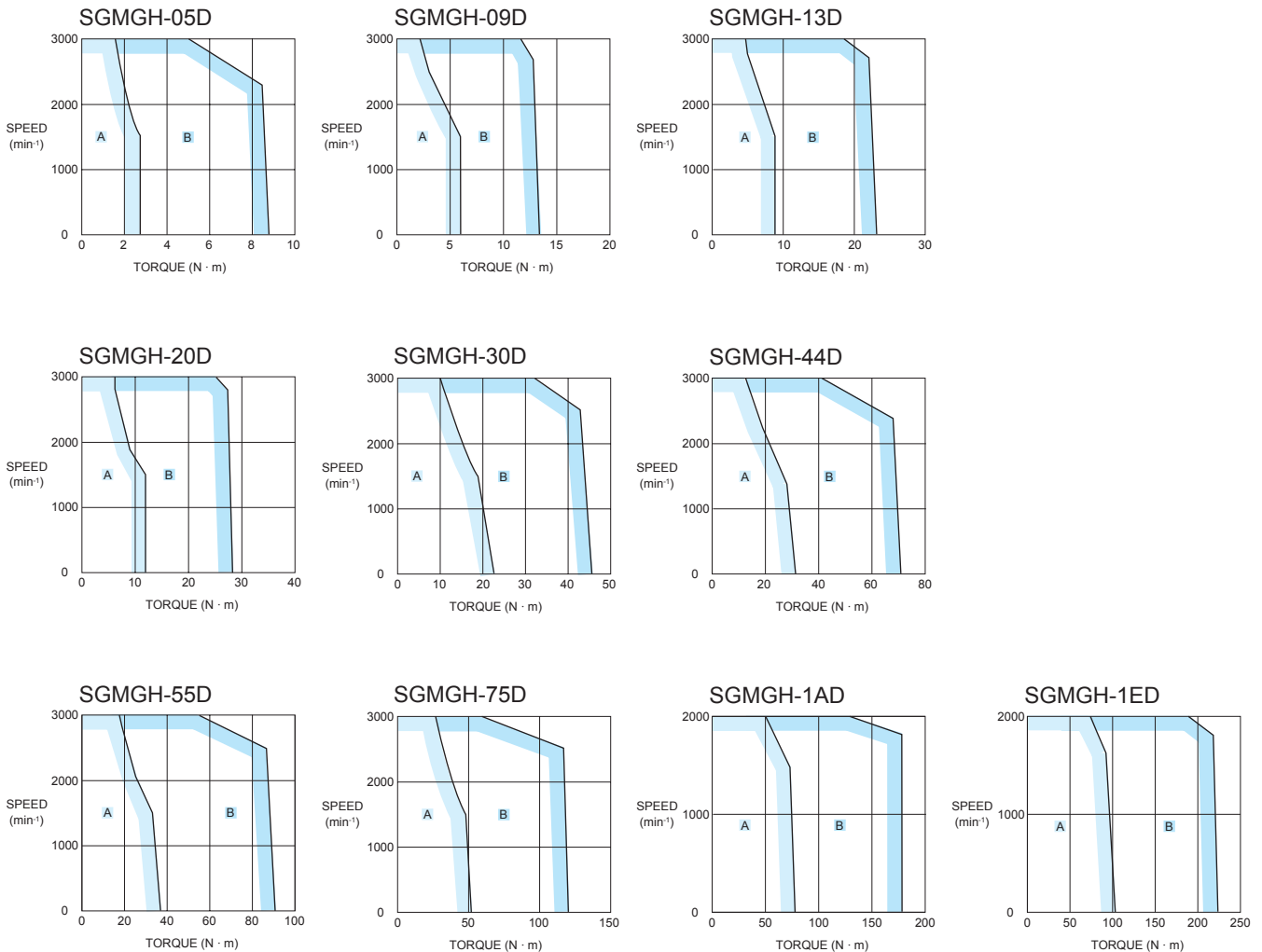

Type SGMSH, 400V

Ratings and Specifications

Applied Voltage		400 V					
Servomotor Model SGMSH-@		10D@	15D@	20D@	30D@	40D@	50D@
Rated Output	kW	1.0	1.5	2.0	3.0	4.0	5.0
Rated Torque	N·m	3.18	4.9	6.36	9.8	12.6	15.8
Instantaneous Peak Torque	N·m	9.54	14.7	19.1	29.4	37.8	47.6
Rated Current	A (rms)	2.8	4.7	6.2	8.9	12.5	13.8
Instantaneous Max. Current	A (rms)	8.5	14	19.5	28	38	42
Rated Speed	min ⁻¹	3000					
Max. Speed	min ⁻¹	5000					
Torque Constant	N·m/A (rms)	1.27	1.15	1.12	1.19	1.07	1.24
Rotor Moment of Inertia (JM)	kg·m ² ×10 ⁻⁴	1.74	2.47	3.19	7.0	9.60	12.3
Allowable Load Moment of Inertia (JL)	Multiple of (JM)	5					
Rated Power Rate	kW/s	57.9	97.2	127	137	166	202
Rated Angular Acceleration	rad/s ²	18250	19840	19970	14000	13160	12780
Applicable Encoder	Standard	Incremental Encoder (17 bits: 16384P/R)					
	Option	Absolute Encoder (17 bits: 16384P/R)					
Holding Brake Moment of Inertia J	kg·m ² ×10 ⁻⁴	0.325				2.10	
Basic Specifications	Time Rating	Continuous					
	Insulation Class	Class F					
	Ambient Temperature	0 to +40° C					
	Ambient Humidity	20 to 80% (non-condensing)					
	Vibration Class	15µm or below					
	Enclosure	Totally-enclosed, self-cooled, IP67 (excluding shaft opening)					
	Vibration Resistance	Vibration acceleration 24.5m/s ²					
	Mounting	Flange-mounted					

Torque-Speed Charecteristics

(A : Continuous Duty Zone B : Intermittent Duty Zone)

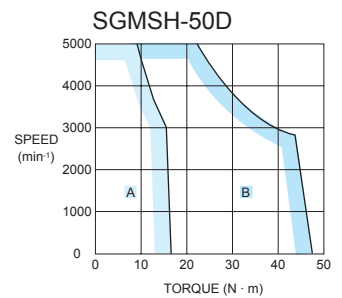
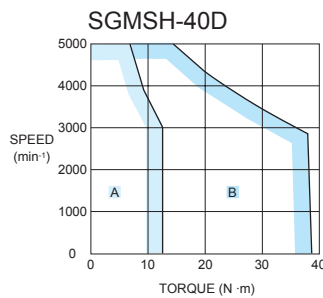
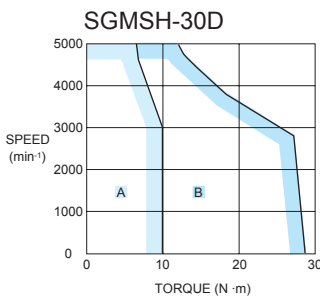
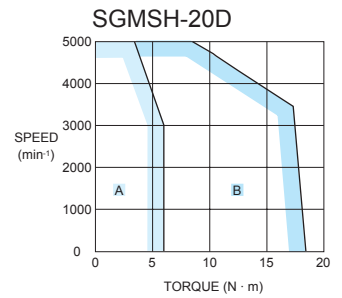
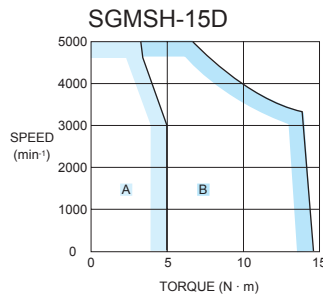
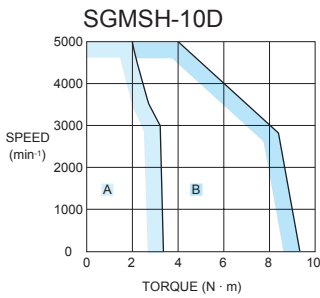

Type SGMUH, 400V

Ratings and Specifications

Applied Voltage		400 V			
Servomotor Model SGMUH-@		10D@	15D@	30D@	40D@
Rated Output	kW	1.0	1.5	3.0	4.0
Rated Torque	N·m	1.59	2.45	4.9	6.3
Instantaneous Peak Torque	N·m	6.5	11	21.5	29
Rated Current	A (rms)	2.7	4.1	8.1	9.6
Instantaneous Max. Current	A (rms)	8.5	14	28	38.5
Rated Speed	min ⁻¹	6000			
Max. Speed	min ⁻¹	6000			
Torque Constant	N·m/A (rms)	0.81	0.83	0.81	0.80
Rotor Moment of Inertia (JM)	kg·m ² ×10 ⁻⁴	1.74	2.47	7.0	9.6
Allowable Load Moment of Inertia (JL)	Multiple of (JM)	5			
Rated Power Rate	kW/s	14.5	24.3	34.3	41.3
Rated Angular Acceleration	rad/s ²	9130	9910	7000	6550
Applicable Encoder	Standard	Incremental Encoder (17 bits: 16384P/R)			
	Option	-			
Holding Brake Moment of Inertia J	kg·m ² ×10 ⁻⁴	0.25		2.10	
Basic Specifications	Time Rating	Continuous			
	Insulation Class	Class F			
	Ambient Temperature	0 to +40° C			
	Ambient Humidity	20 to 80% (non-condensing)			
	Vibration Class	15µm or below			
	Enclosure	Totally-enclosed, self-cooled, IP67 (excluding shaft opening)			
	Vibration Resistance	Vibration acceleration 24.5m/s ²			
	Mounting	Flange-mounted			

Torque-Speed Charecteristics

(A : Continuous Duty Zone B : Intermittent Duty Zone)

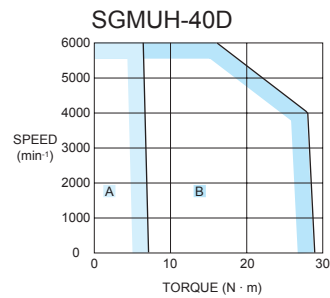
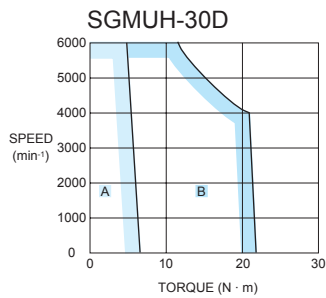
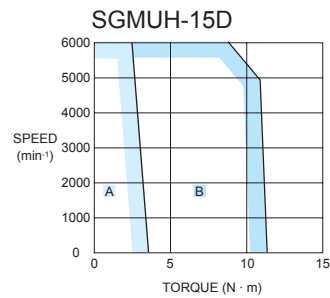
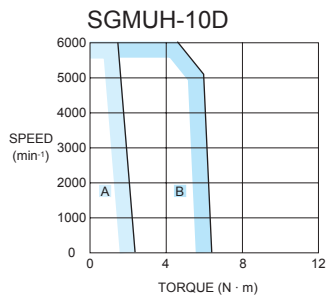

Servo Drive Specifications

Single-Phase, 230 V

Servo Drive Type		SGDH-@	A3AE-OY	A5AE-OY	01AE-OY	02AE-OY	04AE-OY	08AE-OY	15AE-S-OY	
Applicable Servomotor	SGMAH-@	A3A@	A5A@	01A@	02A@	04A@	08A@	-	-	
	SGMPH-@	-	-	01A@	02A@	04A@	08A@	15A@	-	
Max. Applicable Motor capacity		W	30	50	100	200	400	750	1500	
Continuous Output Current		Arms	0.44	0.64	0.91	2.1	2.8	5.7	11.6	
Max. Output Current		Arms	1.3	2.0	2.8	6.5	8.5	13.9	28	
Input Power		Main Circuit	For single-phase, 200 to 230 VAC + 10 to -15%					220 to 230 VAC		
Supply		Control Circuit	For single-phase, 200 to 230 VAC + 10 to -15%					+10 to -15% (50/60Hz)		
Control Method		Single phase full-wave rectification / IGBT / PWM / sine-wave current drive method								
Feedback		Serial encoder (incremental/absolute value)								
Conditions	Usage /storage Temperature		0 to +55° C / -20 to 85° C							
	Usage /storage Humidit		90%RH or less (non-condensing)							
	Altitude		1000m or less above sea level							
	Vibration/Shock Resistance		4.9m/s ² / 19.6m/s ²							
Configuration		Base mounted								
Approx. Mass		Kg	0.8				1.1	1.7	3.8	

Three-Phase, 400 V

Servo Drive Type		SGDH-@	05DE-OY	10DE-OY	15DE-OY	20DE-OY	30DE-OY	50DE-OY	60DE-OY	75DE-OY	1ADE-OY	1EDE-OY
Applicable Servomotor	SGMGH-@	05D@	09D@	13D@	20D@	30D@	44D@	55D@	75D@	1AD@	1ED@	
	SGMSH-@	-	10D@	15D@	20D@	30D@	40D@/50D@	-	-	-	-	
	SGMUH-@	-	10D@	15D@	-	30D@	40D@	-	-	-	-	
Max. Applicable Motor capacity		kW	0.45	1.0	1.5	2.0	3.0	5.0	6.0	7.5	11	15
Continuous Output Current		Arms	1.9	3.5	5.4	8.4	11.9	16.5	20.8	25.4	28.1	37.2
Max. Output Current		Arms	5.5	8.5	14	20	28	40.5	55	65	70	85
Input Power		Main Circuit	For three-phase, 380 to 480 VAC + 10 to -15% (50/60Hz)									
Supply		Control Circuit	24VDC+ 15%									
Control Method		Single phase full-wave rectification / IGBT / PWM / sine-wave current drive method										
Feedback		Serial encoder (incremental/absolute value)										
Conditions	Usage /storage Temperature		0 to +55° C / -20 to +85 C									
	Usage /storage Humidit		90%RH or less (non-condensing)									
	Altitude		1000m or less above sea level									
	Vibration/Shock Resistance		4.9m/s ² / 19.6m/s ²									
Configuration		Base mounted										
Approx. Mass		Kg	2.8			3.8		5.5	15		22	

General Specifications

Specification Category	Speed/Torque Control Mode		Performance	
	Speed/Torque Control Mode	Performance	Speed Control Range: 1:5000 Speed Variance: Load Variance: During 0 to 100% load ±0.01% max. (at rated speed) Voltage Variance: Rated voltage ±10%:0% (at rated speed) Temperature Variance: 25 ±25° C: ±0.1 % max (at rated speed) Frequency characteristics: 400Hz (at J _L = J _M) Torque Control Accuracy (Reproducibility): ±2% Soft Start Time Setting: 0 to 10s (Acceleration, deceleration can each be set.)	
Input Signal	Input Signal	Speed Reference Input	Reference Voltage: ±6VDC (forward motor rotation if positive reference) at rated speed: Set at delivery Variable setting range: ±2 to ±10 VDC at rated speed/ max. input voltage: ±12V Input Impedance: Approx. 14 kΩ Circuit Time Constant: -	
		Torque Reference Input	Reference Voltage: ±3 VDC (forward rotation if positive reference) at rated speed: Set at delivery Variable setting range ±1 to ±10 VDC at rated torque reference Input Impedance: Approx. 14 KΩ Circuit Time Constant: Approx. 47μ s	
		Control Signal	Clear Signal (input pulse is same as reference pulse)	
Position Control Mode	Position Control Mode	Performance	Bias Setting: 0 to 450 min ⁻¹ (setting resolution: 1 min ⁻¹) Feed Forward Compensation: 0 to 100 % (setting resolution: 1%) Position Completed Width Setting: 0 to 250 command units (Setting resolution: 1 command unit)	
		Input Signal	Command Pulse	Input pulse Type: Sign + pulse train, 90° phase displacement 2-phase pulse (A-phase+ B-phase) or CCW/CW pulse train Input Pulse Form: Line driver (+5V level) , open collector (+5V or +12 level) Input Pulse Frequency: 0 to 500 Kpps (200Kpps max. at open collector)
			Control Signal	Clear Signal (input pulse is same as reference pulse)
I/O Signal	I/O Signal	Position Signal Output	A-phase, B.phase, C-phase, (S-phase): Line driver output S-phase is for absolute encoder only.	
		Sequence Input Signal	Servo ON, P control (or control mode switching, zero clamp, command pulse inhibit), forward/reverse run prohibit, alarm reset, forward/ reverse current limit (or internal speed switching)	
Sequence Output Signal		Servo alarm, alarm codes (3-bit output): CN1 output terminal is fixed It is possible to output three types of signals form among: positioning complete (speed agree), motor rotation, servo ready, current limit, speed limit, brake release, warning, NEAR, and zero point pulse signal		

Communications	Interface	Digital operator (hand-held type), RS-422 port for PCs, etc. (RS-232C ports under some conditions)
	1:N Communications	N may equal up to 14 when an RS-422A port is used
	Axis Address Setting	Set by user setting
	Functions	Status display, user constant setting monitor display, alarm traceback display, JOG run /autotuning operations, and graphing functions for speed/torque command signal, etc
Integrated Functions	Auto Tuning Function	Position speed loop gain and integral time constant can be automatically set.
	Dynamic Brake (DB)	Operates during main power OFF, servo alarm, servo OFF or overtravel
	Regenerative Processing	Regenerative resistor externally mounted (option)
	Overtravel (OT) Prevention Function	DB stop, deceleration stop or coast to stop during P-OT, N-OT operation
	Encoder Divider Function	Optional division possible
	Electronic Gearing	0,01 < A/B < 100
	Internal Speed Setting Function	3 speeds may be set internally
	Protective Functions	Overcurrent, overvoltage, insufficient voltage, overload, main circuit sensor error, heatsink overheat, power phase loss, overflow, overspeed, encoder error, runaway, CPU error, parameter error, etc.
	Analog Monitor Functions for Supervision	Integrates analog monitor connectors for supervision of the speed and torque reference signals, etc.
	Display Functions	CHARGE, POWER, 7-segments LEDx5 (Integrated digital operator function)
Others	Reverse connection, zero search, automatic motor discrimination function, and DC reactor connection terminal for high frequency power suppression function (except: 6 to 15kW)	

I/O Specifications

I/O Signals (CN1) - Input signals

Pin No.	Signal Name	Function		
40	Common	/S-ON Servo ON: Turns ON the servomotor when the gate block in the inverter is released.		
41	/P-CON	Function selected by parameter.		
		Proportional control reference	Switches the speed control loop from PI (proportional/integral) to P (proportional) control when ON.	
		Direction reference	With the internal set speed selected: Switch the rotation direction.	
		Control mode switching	Position ↔ speed Position ↔ torque Torque ↔ speed	Enables control mode switching.
		Zero-clamp reference	Speed control with zero-clamp function: Reference speed is zero when ON.	
		Reference pulse block	Position control with reference pulse stop: Stops reference pulse input when ON.	
42	P-OT N-OT	Forward run prohibited	Overtravel prohibited: Stops servomotor when movable part travels beyond the allowable range of motion.	
43		Reverse run prohibited		
45	/P-CL /N-CL	Function selected by parameter.		
		Forward external torque limit ON	Current limit function enabled when ON.	
		Reverse external torque limit ON		
46		Internal speed switching	With the internal set speed selected: Switches the internal speed settings.	
44	/ALM-RST	Alarm reset: Releases the servo alarm state.		
47	+24VIN	Control power supply input for sequence signals: Users must provide the +24 V power supply. Allowable voltage fluctuation range: 11 to 25 V		
4 (2)	SEN	Initial data request signal when using an absolute encoder.		
21	BAT (+)	Connecting pin for the absolute encoder backup battery.		
22	BAT (-)	Do not connect when a battery is connected to the host controller.		
5 (6)	Speed	V-REF Speed reference speed input: ±2 to ±10 V/rated motor speed (Input gain can be modified using a parameter.)		
9 (10)	Torque	T-REF Torque reference input: ±1 to ±10 V/rated motor torque (Input gain can be modified using a parameter.)		
7	Position	PULS /PULS	Reference pulse input for only line driver	Input mode is set from the following pulses. Sign + pulse string CCW/CW pulse Two-phase pulse (90° phase differential)
8				
11		CLR	Positional error pulse clear input: Clears the positional error pulse during position control.	
12		/CLR		
15		PL1 PL2 PL3	+12 V pull-up power is supplied when PULS, SIGN, and CLR reference signals are open-collector outputs (+12 V power supply is built into the SERVOPACK).	
14				
3				
13				
18				

Note: 1. Pin numbers in parentheses () indicate signal grounds.

2. The functions allocated to /S-ON, /P-CON, P-OT, N-OT, /ALM-RST, /P-CL, and /N-CL input signals can be changed by using the parameters.

3. The voltage input range for speed and torque references is a maximum of ±12 V.

I/O Signals (CN1) - Output signals

Pin No.	Signal Name	Function	
31 32	Common	ALM+ ALM-	Servo alarm: Turns OFF when an error is detected.
27 28		/TGON+ /TGON-	Detection during servomotor rotation: Detects when the servomotor is rotating at a speed higher than the motor speed setting. Detection speed can be set by using the parameters.
29 30		/S-RDY+ /S-RDY-	Servo ready: ON if there is no servo alarm when the control/main circuit power supply is turned ON.
33 (1) 34		PAO /PAO	Phase-A signal Converted two-phase pulse (phases A and B) encoder output signal and zero-point pulse (phase C) signal: RS-422 or the equivalent (Proper line receiver is SN75175 manufactured by Texas Instruments or the equivalent corresponding to MC3486.)
35 36		PBO /PBO	
19 20		PCO /PCO	
48 49		PSO /PSO	Phase-S signal With an absolute encoder: Outputs serial data corresponding to the number of revolutions (RS-422 or the equivalent)
37 38 39 (1)		ALO1 ALO2 ALO3	Alarm code output: Outputs 3-bit alarm codes. Open-collector: 30 V and 20 mA rating maximum
Shell		FG	Connected to frame ground if the shield wire of the I/O signal cable is connected to the connector shell.
25 26		Speed	/V-CMP+ /V-CMP-
25 26	Position	/COIN+ /COIN-	Positioning completed (output in Position Control Mode): Turns ON when the number of positional error pulses reaches the value set. The setting is the number of positional error pulses set in reference units (input pulse units defined by the electronic gear).
-	Reserved	/CLT /VLT /BK /WARN /NEAR	Reserved terminals The functions allocated to /TGON, /S-RDY, and /V-CMP (/COIN) can be changed by using the parameters. /CLT, /VLT, /BK, /WARN, and /NEAR signals can also be changed.
16 17 23 24 50	-	-	Terminals not used Do not connect relays to these terminals.

Note: 1. Pin numbers in parentheses () indicate signal grounds.

2. The functions allocated to /TGON, /S-RDY, and /V-CMP (/COIN) can be changed by using the parameters. /CLT, /VLT, /BK, /WARN, and /NEAR signals can also be changed.

Terminal Specifications

Symbol	Name	Function		
L1, L2 or L1, L2, L3	Main circuit AC input terminal	AC power input terminals for the main circuit		
U V W	Servomotor connection terminal	Red White Blue	Terminals for outputs to the Servomotor.	
L1C, L2C		Control power input terminal		AC power input terminals for the control circuit.
⊕		Frame ground		Ground terminal. Ground to a maximum of 100Ω. (class 3)
B1, B2 or B1, B2, B3	Main circuit DC output terminal	5 kW or less: Connect an external regenerative resistor if regenerative energy is high. 5.5 kW: There is no internal regenerative resistor. Be sure to connect an external Regenerative Resistor Unit.		
⊕1, ⊕2	DC reactor connection terminal for suppressing power supply harmonic waves	Normally, short ⊕1 and ⊕2. If a countermeasure against power supply harmonic waves is needed, connect a DC reactor between ⊕1 and ⊕2.		
⊕	Main circuit DC output terminal (positive)	Normally, not connected. This terminal exists on the Servo Drives with a capacity of 6.0 kW or higher only.		
⊖	Main circuit DC output terminal (negative)	Normally, not connected.		

Encoder Connector (CN2)

Pin No.	Signal Name	Function
1	E5V	Encoder power supply + 5V
2	E0V	Encoder power supply ground
3	BAT+	Battery + (used only with absolute encoder)
4	BAT-	Battery - (used only with absolute encoder)
5	S+	Encoder serial signal input
6	S-	Encoder serial signal input

Operation

Operating Functions

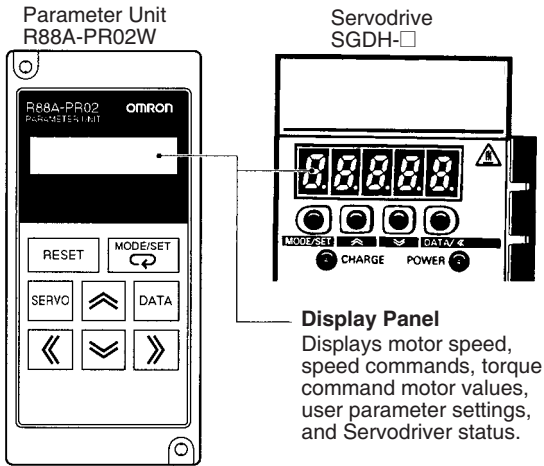

Unit Keys

R88A-PR02W	SGDH-□	Function
RESET		Resets an alarm.
MODE/SET		Switches between status display mode, system check mode, setting mode, and monitor mode. Used as a data setting key while in setting mode.
SERVO		Turns ON or OFF the Servo while jog operations are being performed.
DATA		Switches between parameter display and data display, and records data.
		Increments parameter settings. Used as a forward rotation start key during jog operation.
		Decrements parameter settings. Used as a reverse rotation start key during jog operation.
		Selects the digit whose setting is to be changed. When selected, the digit flashes.

Changing Modes

To change modes, press the MODE/SET Key.

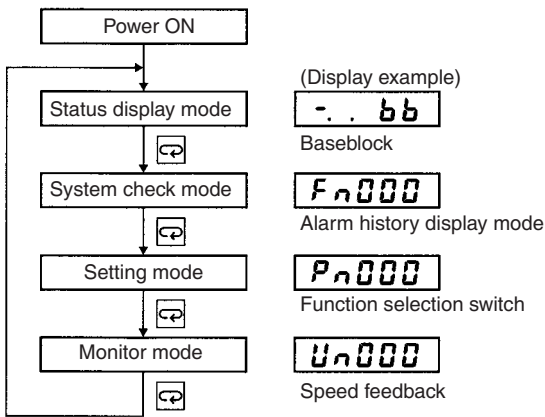

Mode Details

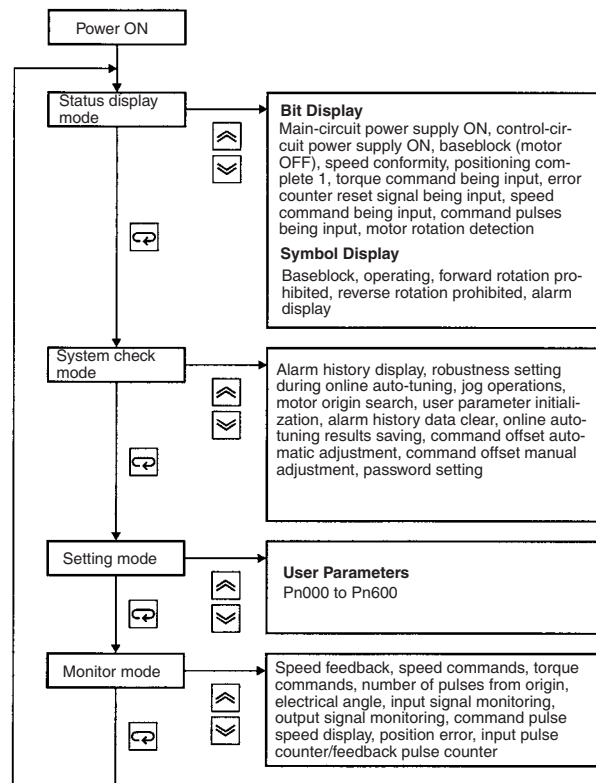

Status Display Mode

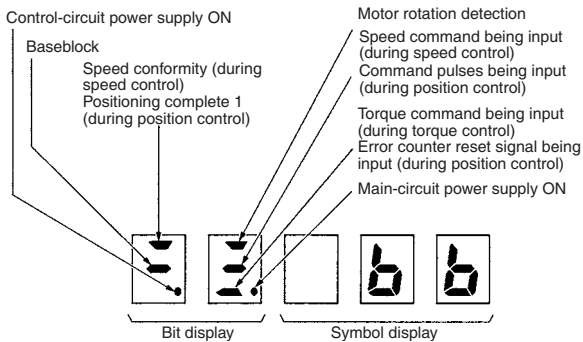

Symbol	Status
bb	Baseblock (motor OFF)
rUn	Operating
p%t	Forward rotation prohibited (forward overtravel)
n%t	Reverse rotation prohibited (reverse overtravel)
a.02	Alarm display

Parameters

Parameter No.	Name	Setting Range	Units	Factory Setting	Setting Validation
Pn000	Function Selection Basic Switches	-	-	0000	After restart
	Digit	Function name	Setting	Explanation	
	0	Direction Selection	0	Sets CCW as forward direction	
			1	Sets CW as forward direction (Reserve Rotation Mode)	
			2 and 3	Reserved (Do not change.)	
	1	Control Method Selection	0	Speed control (analog reference)	
			1	Position control (pulse train reference)	
			2	Torque control (analog reference)	
			3	Internal set speed control (contact reference)	
			4	Internal set speed control (contact reference)<->Speed control (analog reference)	
			5	Internal set speed control reference<->Position control (pulse train reference)	
			6	Internal set speed control (contact reference)<->Torque control (analog reference)	
			7	Position control (pulse train reference)<->Speed control (analog reference)	
			8	Position control (pulse train reference)<->Torque control (analog reference)	
9			Torque control (analog reference)<->Speed control (analog reference)		
A			Speed control (analog reference)<->Zero clamp		
B	Position control (pulse train reference)<->Position control (Inhibit)				
2	Axis Address	0 to F	Sets ServoDrive axis address (Function supported by PC software SigmaWin 100/200).		
3	Rotation Type/Linear Type Startup Selection	0	Starts up as rotation type.		
		1	Starts up as linear type.		
Pn001	Function Selection Application Switches 1	-	-	0000	After restart
	Digit	Function name	Setting	Explanation	
	0	Servo OFF or Alarm Stop Mode	0	Stops the motor by applying dynamic brake (DB)	
			1	Stops the motor by applying dynamic brake (DB) and then releases DB	
			2	Makes the motor coast to a stop state without using the dynamic brake (DB)	
	1	Overtravel (OT) Stop Mode	0	Same setting as Pn001.0 (Stops the motor by applying DB or by coasting)	
			1	Sets the torque of Pn406 to the maximum value, decelerate the motor to a stop, and then set it to servolock state	
			2	Sets the torque of Pn406 to the maximum value. decelerates the motor to a stop, and then sets it to coasting state	
	2	AC/DC Power Input Selection	0	Not applicable to DC power input: Input AC power supply through L1, L2 (,and L3) terminals	
			1	Applicable to DC power input: Input DC power supply between (+1) and (-)	
3	Warning Code Output Selection	0	ALO1, ALO2, and ALO3 output only alarm codes.		
		1	ALO1, ALO2, and ALO3 output both alarms codes and warning codes. While warning codes are output, ALM signal output remains ON (normal state).		
Pn002	Function Selection Application Switches 2	-	-	0000	After restart
	Digit	Function name	Setting	Explanation	
	0	Speed Control Option	0	N/A	
			1	Uses T-REF as an extended	
			2	Uses T-REF as an external torque limit input when P-CL and N-CL are ON.	
	1	Torque Control Option	0	N/A	
			1	Uses V-REF as an external speed limit input.	
	2	Absolute Encoder Usage	0	Uses absolute encoder as an absolute encoder	
			1	Uses absolute encoder as an incremental encoder	
	3	Reserved (Do not change)			
Pn003	Function Selection Application Switches 3	-	-	0002	After restart
	Digit	Function name	Setting	Explanation	
	0	Analog Monitor 1 Torque Reference Monitor	0	Motor speed: 1V/1000 min ⁻¹	
			1	Speed reference: 1V/1000 min ⁻¹	
			2	Torque reference: 1 V/100%	
			3	Position error: 0,05 V/1 reference unit	
			4	Position error:0,05 V/100 reference units	
			5	Reference pulse frequency (converted to min ⁻¹ : 1V/1000 min ⁻¹	
			6	Motor Speed x 4: 1V/250 min ⁻¹	
			7	Motor Speed x 8: 1V/250 min ⁻¹	
	8 to F	Reserved (Do not change)			
	1	Analog Monitor 2 Speed Reference Monitor	0 to F	Same as Analog Monitor 1 Torque Reference Monitor	
	2	Reserved (Do not change)			
3	Reserved (Do not change)				
Pn004	Reserved (Do not change)	-	-	0000	Immediately
Pn005	Reserved (Do not change)	-	-	0000	Immediately
Pn100	Speed Loop Gain	1 to 2000 Hz	1 Hz	40 Hz	Immediately
Pn101	Speed Loop Integral Time Constant	0.15 to 512.00 ms	0.01 ms	20.00 ms	Immediately
Pn102	Position Loop Gain	1 to 2000/s	1/s	40/s	Immediately
Pn103	Moment of Inertia Ratio	0 to 20000%	1%	0%	Immediately
Pn104	2nd Speed Loop Gain	1 to 2000 Hz	1 Hz	40 Hz	Immediately

Parameter No.	Name	Setting Range	Units	Factory Setting	Setting Validation		
Pn105	2nd Speed Loop Integral Time Constant	0.15 to 512.00 ms	0.01 ms	20.00 ms	Immediately		
Pn106	2nd Position Loop Gain	1 to 2000/s	1/s	40/s	Immediately		
Pn107	Bias	0 to 450 min ⁻¹	1 min ⁻¹	0 min ⁻¹	Immediately		
Pn108	Bias Width Addition	0 to 250 reference units	Reference unit	7 reference units	Immediately		
Pn109	Feed-forward	0 to 100%	1%	0%	Immediately		
Pn10A	Feed-forward Filter Time Constant	0.00 to 64.00 ms	0.01 ms	0.00 ms	Immediately		
Pn10B	Gain-related Application Switches		-	-	0000	-	
	Digit	Function name	Setting	Explanation		Setting Validation	
	0	Mode Switch Selection	0	Uses internal torque reference as the condition (Level setting: Pn10C)			Immediately
			1	Uses speed reference as the condition (Level setting: Pn10D)			
			2	Uses acceleration as the condition (Level setting: Pn10E)			
			3	Uses position error pulse as the condition (Level setting: P10F)			
			4	No mode switch function available			
	1	Speed Loop Control Method	0	PI control			After restart
			1	IP control			
			2 and 3	Reserved (Do not change)			
	2	Automatic Gain Switching Selection	0	Automatic Gain Switching Disabled			After restart
			1	Position Reference			
			2	Position error			
3			Position Reference and Position Error				
3	Reserved (Do not change)						
Pn10C	Mode Switch Torque Reference	0 to 800%	1%	200%	Immediately		
Pn10D	Mode Switch Speed Reference	0 to 10000 min ⁻¹	1 min ⁻¹	0 min ⁻¹	Immediately		
Pn10E	Mode Switch Acceleration	0 to 3000 min ⁻¹ /s	1 min ⁻¹ /s	0 min ⁻¹ /s	Immediately		
Pn10F	Mode Switch Error Pulse	0 to 10000 reference units	1 reference unit	0 reference unit	Immediately		
Pn110	Online Autotuning Switches *1		-	-	0010	-	
	Digit	Function name	Setting	Explanation		Setting Validation	
	0	Online Autotuning Method	0	Tunes only at the beginning operation			After restart
			1	Always tunes.			
			2	Does not perform autotuning.			
	1	Speed feedback Compensation Selection	0	Applicable			Immediately
			1	N/A			
	2	Friction Compensation Selection	0	Friction compensation: Disabled			Immediately
			1	Friction compensation: Small			
			2	Friction compensation: Large			
3	Reserved (Do not change)						
Pn111	Speed Feedback Compensation *2	1 to 500%	1%	100%	Immediately		
Pn112	Reserved (Do not change)	-	-	100%	-		
Pn113				1000			
Pn114				200			
Pn115				32			
Pn116				16			
Pn117				100%			
Pn118				100%			
Pn119				50 /s			
Pn11A				1000%			
Pn11B				50 Hz			
Pn11C				70 Hz			
Pn11D				100%			
Pn11E				100%			
Pn11F				0 ms			
Pn120				0 ms			
Pn121	50 Hz						
Pn122	0 Hz						
Pn123	0%						
Pn124	Automatic Gain Switching Timer	1 to 10000 ms	1 ms	100 ms	Immediately		
Pn125	Automatic Gain Switching Width	1 to 250 reference units	1 reference	7 reference units	Immediately		

Parameter No.	Name	Setting Range	Units	Factory Setting	Setting Validation
Pn200	Position Control References Selection Switches	-	-	0000	After restart
	Digit Function Name	Setting	Explanation		
	0 Reference Pulse Form	0	Sign + Pulse, positive logic		
		1	CW + CCW, positive logic		
		2	Phase A + Phase B (x 1), positive logic		
		3	Phase A + Phase B (x 2), positive logic		
		4	Phase A + Phase B (x 4), positive logic		
		5	Sign + Pulse, negative logic		
		6	CW + CWW, negative logic		
		7	Phase A + Phase B (x 1), negative logic		
		8	Phase A + Phase B (x 2), negative logic		
		9	Phase A + Phase B (x 4), negative logic		
	1 Error Counter Clear	0	Clears error counter when the signal is at H level		
		1	Clears error counter at the rising edge of the signal		
		2	Clears error counter when the signal is at L level.		
		3	Clears error counter at the falling edge of the signal		
	2 Clear Operation	0	Clear error counter at the baseblock		
		1	Does not clear error counter (Only possible to clear error counter with CLR signal)		
		2	Clears error counter when an alarm occurs.		
	3 Filter Selection	0	Reference input filter for line driver signals		
		1	Reference input filter for open collector signals		
Pn201	PG Dividing Pulse (16bit or less)	16 to 16384 P/rev	1 P/rev	16384 P/rev	After restart
Pn202	Electronic Gear Ratio (Numerator)	1 to 65535	-	4	After restart
Pn203	Electronic Gear Ratio (Denominator)	1 to 65535	-	1	After restart
Pn204	Position Reference Accel/Decel Time Constant	0.00 to 64.00 ms	0.01 ms	0.00 ms	Immediately
Pn205	Multiturn Limit Setting *	0 to 65535 rev	rev	65535 rev	After restart
Pn206	Reserved (Do not change)	-	-	16384 P/rev	-
Pn207	Position Control Function Switches			0000	After restart
	Digit Function Name	Setting	Explanation		
	0 Position Reference Filter selection	0	Acceleration/deceleration filter		
		1	Average movement filter		
	1 Position Control Option	0	N/A		
		1	Uses V-REF as a speed feed-forward input		
	2 Dividing Pulse Parameter Selection	0	Use Pn201 (16-bit or less)		
		1	Use Pn212 (17-bit or more)		
	3 Reserved (Do not change)				
Pn208	Position Reference Movement Averaging Time	0.00 to 64.00 ms	0.01 ms	0.00 ms	After restart
Pn212	PG Dividing Pulse (17 bit or more)*	16 to 1073741824 P/rev	1 P/rev	2048P/rev	After restart
Pn217	Reference Pulse Input Multiplication	×1 to ×99	× 1	×1	Immediately
Pn218	Reference Pulse Multiplication Function Selection	-	-	0000	After restart
	Digit Function Name	Setting	Explanation		
	0 Reference Pulse Multiplication Function Selection	0	Disabled		
		1	Enabled		
	1 Reserved (Do not change)				
	2 Reserved (Do not change)				
	3 Reserved (Do not change)				
Pn300	Speed Reference Input Gain	1.50 to 30.00 V/ rated speed	0.01V/ rated speed	6.00 V/ rated speed	Immediately
Pn301	Speed 1	0 to 10000 min ⁻¹	1 min ⁻¹	100 min ⁻¹	Immediately
Pn302	Speed 2	0 to 10000 min ⁻¹	1 min ⁻¹	200 min ⁻¹	Immediately
Pn303	Speed 3	0 to 10000 min ⁻¹	1 min ⁻¹	300 min ⁻¹	Immediately
Pn304	JOG Speed	0 to 10000 min ⁻¹	1 min ⁻¹	500 min ⁻¹	Immediately
Pn305	Soft Start Acceleration Time	0 to 10000 ms	1 ms	0 ms	Immediately
Pn306	Soft Start Deceleration Time	0 to 10000 ms	1 ms	0 ms	Immediately
Pn307	Speed Reference Filter Time Constant	0.00 to 655.35 ms	0.01 ms	0.40 ms	Immediately
Pn308	Speed Feedback Filter Time Constant	0.00 to 655.35 ms	0.01 ms	0.00 ms	Immediately
Pn309	Reserved (Do not change)	0 - 500 min ⁻¹	1 min ⁻¹	60 min ⁻¹	Immediately
Pn400	Torque Reference Input Gain	1.0 to 10.0 V/rated torque	0.1 V/rated torque	3.0 V/ rated torque	Immediately
Pn401	Torque Reference Filter Time Constant	0.00 to 655.35 ms	0.01 ms	1.00 ms	Immediately
Pn402	Forward Torque Limit	0 to 800%	1%	800%	Immediately
Pn403	Reverse Torque Limit	0 to 800%	1%	800%	Immediately
Pn404	Forward External Torque Limit	0 to 800%	1%	100%	Immediately
Pn405	Reverse External Torque Limit	0 to 800%	1%	100%	Immediately
Pn406	Emergency Stop Torque	0 to 800%	1%	800%	Immediately
Pn407	Speed Limit during Torque Control	0 to 10000 min ⁻¹	1 min ⁻¹	10000 min ⁻¹	Immediately

Parameter No.	Name	Setting Range	Units	Factory Setting	Setting Validation
Pn408	Torque Function Switches	-	-	0000	Immediately
	Digit Function Name	Setting	Explanation		
	0 Notch Filter Selection	0	N/A		
		1	Uses a notch filter for torque reference		
	1 Reserved (Do not Change)				
	2 2nd Notch Filter Selection	0	Disabled		
		1	Enabled		
	3 Reserved (Do not Change)				
Pn409	Notch Filter Frequency	50 to 2000 Hz	1 Hz	2000 Hz	Immediately
Pn40A	Notch Filter Q Value	50 to 400(0.50 to 4.00)	0.01	70(0.70)	Immediately
Pn40B	2nd Notch Filter Frequency	50 to 2000 Hz	1 Hz	2000 Hz	Immediately
Pn40C	2nd Notch Filter Q Value	50 to 400 (0.50 to 4.00)	0.01	70(0.70)	Immediately
Pn500	Positioning Completed Width	0 to 250 reference units	1 reference unit	7 reference units	Immediately
Pn501	Zero Clamp Level	0 to 10000 min ⁻¹	1 min ⁻¹	10 min ⁻¹	Immediately
Pn502	Rotation Detection Level	1 to 10000 min ⁻¹	1 min ⁻¹	20 min ⁻¹	Immediately
Pn503	Speed Coincidence Signal Output Width	0 to 100 min ⁻¹	1 min ⁻¹	10 min ⁻¹	Immediately
Pn504	NEAR Signal Width	1 to 250 reference units	1 reference unit	7 reference units	Immediately
Pn505	Overflow Level	1 to 32767reference units	256 reference unit	1024 reference units	Immediately
Pn506	Brake Reference - Servo OFF Delay Time	1 to 50 (10 to 500 ms)	10 ms	10 ms	Immediately
Pn507	Brake Reference Output Speed Level	0 to 10000 min ⁻¹	1 min ⁻¹	100 min ⁻¹	Immediately
Pn508	Timing for Brake Reference Output during Motor Operation	10 to 100 (100 to 1000 ms)	10 ms	500 ms	Immediately
Pn509	Momentary Hold time	20 to 1000 ms	1 ms	20 ms	Immediately
Pn50A	Input Signal Selections 1	-	-	2100	After restart
	Digit Function Name	Setting	Explanation		
	0 Input Signal Allocation Mode	0	Uses the sequence input signal terminals with standard allocation		
		1	Changes the sequence input signal allocation for each signal		
	1 /S-ON Signal Mapping Signal Polarity:Normal:Servo ON when ON Signal Polarity:Reverse: Servo ON when OFF	0	ON when CN1-40 input signals is ON (L-level).		
		1	ON when CN1-41 input signals is ON (L-level)		
		2	ON when CN1-42 input signals is ON (L-level)		
		3	ON when CN1-43 input signals is ON (L-level)		
		4	ON when CN1-44 input signals is ON (L-level)		
		5	ON when CN1-45 input signals is ON (L-level)		
		6	ON when CN1-46 input signals is ON (L-level)		
		7	Sets signal ON		
		8	Sets signal OFF		
		9	OFF when CN1-40 input signals is OFF (H-level)		
		A	OFF when CN1-41 input signals is OFF (H-level)		
		B	OFF when CN1-42 input signals is OFF (H-level)		
		C	OFF when CN1-43 input signals is OFF (H-level)		
		D	OFF when CN1-44 input signals is OFF (H-level)		
		E	OFF when CN1-45 input signals is OFF (H-level)		
		F	OFF when CN1-46 input signals is OFF (H-level)		
	2 /P-CON Signal Mapping (P control when ON(L-level)	0 to F	Same as /S-ON		
	3 /P-OT Signal Mapping(Overtravel when OFF(H-level)	0	Forward run allowed when CN1-40 input signal is ON (L-level)		
		1	Forward run allowed when CN1-41 input signal is ON (L-level)		
		2	Forward run allowed when CN1-42 input signal is ON (L-level)		
		3	Forward run allowed when CN1-43 input signal is ON (L-level)		
		4	Forward run allowed when CN1-44 input signal is ON (L-level)		
		5	Forward run allowed when CN1-45 input signal is ON (L-level)		
		6	Forward run allowed when CN1-46 input signal is ON (L-level)		
		7	Forward run prohibited.		
		8	Forward run allowed.		
		9	Forward run allowed when CN1-40 input signals is OFF (H-level)		
		A	Forward run allowed when CN1-41 input signals is OFF (H-level)		
		B	Forward run allowed when CN1-42 input signals is OFF (H-level)		
		C	Forward run allowed when CN1-43 input signals is OFF (H-level)		
		D	Forward run allowed when CN1-44 input signals is OFF (H-level)		
		E	Forward run allowed when CN1-45 input signals is OFF (H-level)		
		F	Forward run allowed when CN1-46 input signals is OFF (H-level)		

Parameter No.	Name	Setting Range	Units	Factory Setting	Setting Validation
Pn50B	Input Signal Selections 2	-	-	6543	After restart
	Digit Function Name	Setting	Explanation		
	0 /N-OT Signal Mapping (Overtravel when OFF (H-level))	0	Reserve run allowed when CN1-40 input signals is ON (L-level).		
		1	Reserve run allowed when CN1-41 input signals is ON (L-level).		
		2	Reserve run allowed when CN1-42 input signals is ON (L-level).		
		3	Reserve run allowed when CN1-43 input signals is ON (L-level).		
		4	Reserve run allowed when CN1-44 input signals is ON (L-level).		
		5	Reserve run allowed when CN1-45 input signals is ON (L-level).		
		6	Reserve run allowed when CN1-46 input signals is ON (L-level).		
		7	Reserve run prohibited.		
		8	Reserve run allowed		
		9	Reserve run allowed when CN1-40 input signals is OFF (H-level).		
		A	Reserve run allowed when CN1-41 input signals is OFF (H-level).		
		B	Reserve run allowed when CN1-42 input signals is OFF (H-level).		
		C	Reserve run allowed when CN1-43 input signals is OFF (H-level).		
		D	Reserve run allowed when CN1-44 input signals is OFF (H-level).		
		E	Reserve run allowed when CN1-45 input signals is OFF (H-level).		
		F	Reserve run allowed when CN1-46 input signals is OFF (H-level).		
	1 /ALM-RST Signal Mapping (Alarm Reset when ON(L-level))	0 to F	Same as N-OT		
	2 /P-CL Signal Mapping(Torque Limit when ON(L-level))	0 to F	Same as S-ON, the setting of Pn50A.1		
	3 /N-CL Signal Mapping(Torque Limit when ON(L-level))	0 to F	Same as S-ON, the setting of Pn50A.1		
Pn50C	Input Signal Selections 3	-	-	8888	After restart
	Digit Function Name	Setting	Explanation		
	0 /SPD-D Signal Mapping	0	ON when CN1-40 input signal is ON (L-level).		
		1	ON when CN1-41 input signal is ON (L-level).		
		2	ON when CN1-42 input signal is ON (L-level).		
		3	ON when CN1-43 input signal is ON (L-level).		
		4	ON when CN1-44 input signal is ON (L-level).		
		5	ON when CN1-45 input signal is ON (L-level).		
		6	ON when CN1-46 input signal is ON (L-level).		
		7	Set signal ON.		
		8	Set signal OFF.		
		9	ON when CN1-40 input signal is OFF (H-level).		
		A	ON when CN1-41 input signal is OFF (H-level).		
		B	ON when CN1-42 input signal is OFF (H-level).		
		C	ON when CN1-43 input signal is OFF (H-level).		
		D	ON when CN1-44 input signal is OFF (H-level).		
		E	ON when CN1-45 input signal is OFF (H-level).		
		F	ON when CN1-46 input signal is OFF (H-level).		
	1 /SPD-A Signal Mapping	0 to F	Same as SPD-D		
	2 /SPD-B Signal Mapping	0 to F	Same as SPD-D		
	3 /C-SEL Signal Mapping (Control mode change when ON (L-level))	0 to F	Same as SPD-D		
Pn50D	Input Signal Selections 4	-	-	8888	After restart
	Digit Function Name	Setting	Explanation		
	0 /ZCLAMP Signal Mapping (Zero clamp when ON (L-level))	0	ON when CN1-40 input signal is ON (L-level).		
		1	ON when CN1-41 input signal is ON (L-level).		
		2	ON when CN1-42 input signal is ON (L-level).		
		3	ON when CN1-43 input signal is ON (L-level).		
		4	ON when CN1-44 input signal is ON (L-level).		
		5	ON when CN1-45 input signal is ON (L-level).		
		6	ON when CN1-46 input signal is ON (L-level).		
		7	Set signal ON.		
		8	Set signal OFF.		
		9	ON when CN1-40 input signal is OFF (H-level).		
		A	ON when CN1-41 input signal is OFF (H-level).		
		B	ON when CN1-42 input signal is OFF (H-level).		
		C	ON when CN1-43 input signal is OFF (H-level).		
		D	ON when CN1-44 input signal is OFF (H-level).		
		E	ON when CN1-45 input signal is OFF (H-level).		
		F	ON when CN1-46 input signal is OFF (H-level).		
	1 /INHIBIT Signal Mapping (Reference pulse inhibit when ON (L-level))	0 to F	Same as /Z CLAMP		
	2 /G-SEL Signal Mapping (Gain change when ON (L-level))	0 to F	Same as /Z CLAMP		
	3 Reserved (Do not Change)				

Parameter No.	Name	Setting Range	Units	Factory Setting	Setting Validation	
Pn50E	Output Signal Selections 1	-	-	3211	After restart	
	Digit Function Name	Setting	Explanation			
	0	Positioning Completion Signal Mapping (/COIN)	0	Disabled (the above signal is not used)		
			1	Outputs the signal from CN1-25, 26 output terminal		
			2	Outputs the signal from CN1-27, 28 output terminal		
			3	Outputs the signal from CN1-29, 30 output terminal		
	1	Speed Coincidence Detection Signal Mapping (/V-CMP)	0 to 3	Same as /COIN		
2	Speed Coincidence Detection Signal Mapping (/V-CMP)	0 to 3	Same as /COIN			
3	Speed Coincidence Detection Signal Mapping (/V-CMP)	0 to 3	Same as /COIN			
Pn50F	Output Signal Selections 2	-	-	0000	After restart	
	Digit Function Name	Setting	Explanation			
	0	Torque Limit Detection Signal Mapping (/CLT)	0	Disabled (the above signal is not used)		
			1	Outputs the signal from CN1-25, 26 output terminal		
			2	Outputs the signal from CN1-27, 28 output terminal		
			3	Outputs the signal from CN1-29, 30 output terminal		
	1	Speed Limit Detection Signal Mapping (/VLT)	0 to 3	Same as /CLT		
2	Brake Interlock Signal Mapping (/BK)	0 to 3	Same as /CLT			
3	Warning Signal Mapping (/WARN)	0 to 3	Same as /CLT			
Pn510	Output Signal Selections 3	-	-	0000	After restart	
	Digit Function Name	Setting	Explanation			
	0	Near Signal Mapping (/NEAR)	0	Disabled (the above signal is not used)		
			1	Outputs the signal from CN1-25 or -26 output terminal		
			2	Outputs the signal from CN1-27 or -28 output terminal		
			3	Outputs the signal from CN1-29 or -30 output terminal		
	1	Reserved (Do not Change)	-			
	2	Reference Pulse Input Multiplication Selection Signal Mapping (/PSELA)	0	Disabled (the above signal is not used)		
			1	Outputs the signal from CN1-25 or -26 output terminal		
			2	Outputs the signal from CN1-27 or -28 output terminal		
3			Outputs the signal from CN1-29 or -30 output terminal			
3	Reserved (Do not Change)	-				
Pn511	Reserved (Do not change)	-	-	8888	Immediately	
Pn512	Output Signal Reversal Settings	-	-	0000	After restart	
	Digit Function Name	Setting	Explanation			
	0	Output Signal Reversal for CN1-25 or -26 Terminals	0	Output signal is not reversed		
			1	Output signal is reversed		
	1	Output Signal Reversal for CN1-27 or -28 Terminals	0	Output signal is not reversed		
			1	Output signal is reversed		
	2	Output Signal Reversal for CN1-29 or -30 Terminals	0	Output signal is not reversed		
1			Output signal is reversed			
3	Reserved (Do not Change)	-				
Pn513	Input Signal Selections 5	-	-	0088	After restart	
	Digit Function Name	Setting	Explanation			
	0	/PSEL Signal Mapping (Reference pulse input multiplication when ON (L-level))	0	ON when CN1-40 input signal is ON (L-level).		
			1	ON when CN1-41 input signal is ON (L-level).		
			2	ON when CN1-42 input signal is ON (L-level).		
			3	ON when CN1-43 input signal is ON (L-level).		
			4	ON when CN1-44 input signal is ON (L-level).		
			5	ON when CN1-45 input signal is ON (L-level).		
			6	ON when CN1-46 input signal is ON (L-level).		
			7	Set signal ON.		
			8	Set signal OFF.		
			9	ON when CN1-40 input signal is OFF (H-level).		
			A	ON when CN1-41 input signal is OFF (H-level).		
			B	ON when CN1-42 input signal is OFF (H-level).		
			C	ON when CN1-43 input signal is OFF (H-level).		
			D	ON when CN1-44 input signal is OFF (H-level).		
	E	ON when CN1-45 input signal is OFF (H-level).				
F	ON when CN1-46 input signal is OFF (H-level).					
1	Reserved (Do not change)	-				
2	Reserved (Do not change)	-				
3	Reserved (Do not change)	-				
Pn51A	Position Error Level Between Motor and Load	0 - 32767 Reference Unit	1 Reference Unit	0	Immediately	
Pn51B	Reserved (Do not Change)	1 - 32767 min ⁻¹	1 min ⁻¹	100 min ⁻¹	Immediately	
Pn51C	Reserved (Do not Change)	0 - 10000 %	1%	450 %	Immediately	

Parameter No.	Name	Setting Range	Units	Factory Setting	Setting Validation
Pn51E	Excessive Position Error Warning Level	0 to 100%	1%	0%	Immediately
Pn600	Regenerative Resistor Capacity	Depends on ServoDrive Capacity	10 W	0 W	Immediately
Pn601	Reserved (Do not change)	Depends on Servo Drive-Capacity	-	0 W	Immediately

Monitor Mode Details

Monitor No.	Monitor item	Unit	Explanation
Un000	Speed Feedback	min ⁻¹	Displays the actual motor speed.
Un001	Speed Command	min ⁻¹	Displays the speed command value or internally set speed value during speed control. 0 is displayed during pulse-train input control.
Un002	Torque Command	%	Displays the command value for a current loop that is expressed by treating the rated torque as 100%.
Un003	Number of Pulses from Z-Phase	Pulses	Displays the number of pulses from Z-Phase in encoder resolution units (times 4).
Un004	Electrical Angle	degrees	Displays the motor electrical angle.
Un005	Input Signal Monitor	---	Displays driver I/O signal status by turning ON or OFF each signal bit.
Un006	Output Signal Monitor	---	
Un007	Command Pulse Speed Display	r/min	Displays command pulse frequency converted in r/min.
Un008	Position Deviation (Error Counter)	Reference units	Displays the number of pulses accumulated in the error counter (Position Deviation) that are converted in reference units (input pulse references).
Un009	Motor Load Rate	%	Displays effective torque at intervals of 10 s that is expressed by treating the rated torque as 100%.
Un00A	Regeneration Load Rate	%	Displays the amount of regeneration energy absorbed at intervals of 10 s that is expressed by treating the Pn600 setting (Regenerative Resistor Capacity) as 100%.
Un00B	Dynamic Brake Resistance Load Rate	%	Displays the resistance load factor at intervals of 10 s that is expressed by treating the rated load factor as 100%.
Un00C	Input Pulse Counter	Reference units	Displays the number of counted input pulses in hexadecimal notation.
Un00D	Feedback Pulse Counter	Pulses	Displays the number of counted encoder feedback pulses in hexadecimal notation (multiplied by 4).

List of Function Modes

Parameter No.	Function
Fn000	Alarm traceback data display
Fn001	Rigidity setting during online autotuning
Fn002	JOG mode operation
Fn003	Zero-point search mode
Fn004	Fixed parameter
Fn005	Parameter setting initialization
Fn006	Alarm traceback data clear
Fn007	Writing to EEPROM moment of inertia ratio data obtained from online autotuning
Fn008	Absolute encoder multiturn reset and encoder alarm reset
Fn009	Automatic tuning of analog (speed, torque) reference offset
Fn00A	Manual adjustment of speed reference offset
Fn00B	Manual adjustment of torque reference offset
Fn00C	Manual zero-adjustment of analog monitor output
Fn00D	Manual gain-adjustment of analog monitor output
Fn00E	Automatic offset-adjustment of motor current detection signal
Fn00F	Manual offset-adjustment of motor current detection signal
Fn010	Password setting (protects parameters from being changed)
Fn011	Motor models display
Fn012	Software version display
Fn013	Multiturn limit setting change when a Multiturn Limit Disagreement Alarm (A.CC) occurs
Fn014	Application module detection results clear

Dimensions

Servomotors

Type SGMAH (230/400V)

Dimensions (mm)	Without Brake		With Brake		LR	Flange surface						Shaft end					
	L	LL	L	LL		LA	LB	LC	LE	LG	LZ	S	QK	W	T	U	Tap × Depth
SGMAH-A3A@A6@D-OY	94.5	69.5	126	101	25	46	30 ^{h7/r}	40	2.5	5	4.3	6 ^{h6}	14	2	2	1.2	M2.5 x 5L
SGMAH-A5A@A6@D-OY	102.0	77	133.5	108.5								8 ^{h6}					
SGMAH-01A@A6@D-OY	119.5	94.5	160	135								14 ^{h6}	20	5	5	3	M5 x 8L
SGMAH-02A@A6@D-OY	126.5	96.5	166	136	30	70	50 ^{h7/r}	60	3	6	5.5	14 ^{h6}	20	5	5	3	M5 x 8L
SGMAH-03D@A6@D-OY	154.5	124.5	194	164													
SGMAH-04A@A6@D-OY					40	90	70 ^{h7/r}	80	3	8	7	16 ^{h6}	30				
SGMAH-07D@A6@D-OY	185	145	229.5	189.5													
SGMAH-08A@A6@D-OY																	

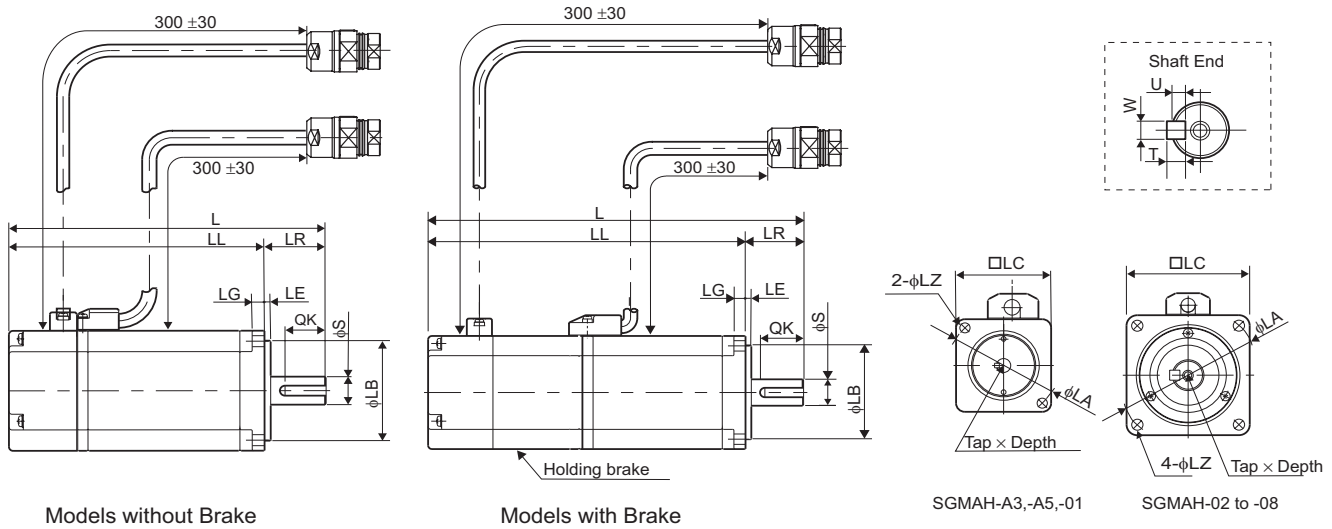

Type SGMPH (230/400V)

Dimensions (mm)	Without Brake		With Brake		LR	Flange surface						Shaft end												
	L	LL	L	LL		LA	LB	LC	LE	LG	LZ	S	QK	W	T	U	Tap × Depth							
SGMPH-01@@@6@D-OY	87	62	116	91	25	70	50 ^{h7/r}	60	3	6	5.5	8 ^{h6}	14	3	3	1.8	M3x6L							
SGMPH-02@@@6@D-OY	97	67	128.5	98.5								30						90	70 ^{h7/r}	80	3	8	7	14 ^{h6}
SGMPH-04@@@6@D-OY	117	87	148.5	118.5								40	145	110 ^{h7/r}	120	3.5	10	10	16 ^{h6}	22	6	6	3.5	M6x10L
SGMPH-08@@@6@D-OY	126.5	86.5	160	120	19 ^{h6}																			
SGMPH-15@@@6@D-OY	154.5	114.5	188	148																				

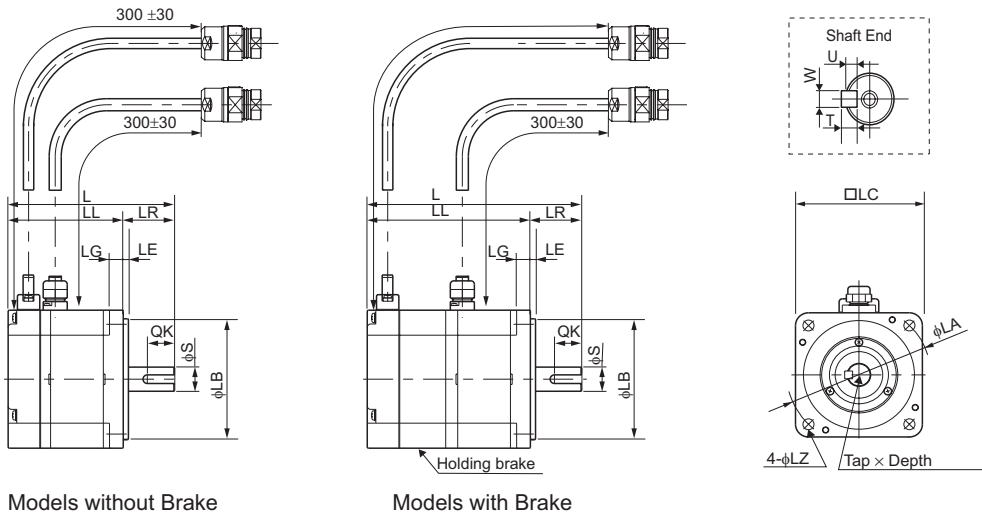

Type SGMGH (400V)

Dimensions (mm)	Without Brake			With Brake				LR	LT	KB1	KL1	Flange surface							Shaft end								
	L	LL	KB2	L	LL	KB2	KB3					KL3	LA	LB	LC	LE	LG	LH	LZ	S	Q	QK	W	T	U	P	
SGMGH-05D@A6@-OY	196	138	117	234	176	154	109	98	58	46	65	109	145	110	130	6	12	165	9	19	40	25	5	5	3	M5x12L	
SGMGH-09D@A6@-OY	219	161	140	257	199	177	132				88									22			6	6	3.5		
SGMGH-13D@A6@-OY	243	185	164	281	223	201	156				112																
SGMGH-20D@A6@-OY	245	166	144	296	217	195	137	123	79	47	89	140	200	114.3	180	3.2	18	230	13.5	35	76	60	10	8	5	M12x25L	
SGMGH-30D@A6@-OY	271	192	170	322	243	221	163				115																
SGMGH-44D@A6@-OY	305	226	204	356	277	255	197				149																
SGMGH-55D@A6@-OY	373	260	238	424	311	289	231		113		174	150								42	110	90	12			M16x32L	
SGMGH-75D@A6@-OY	447	334	312	498	385	363	305				248																
SGMGH-1AD@A6@-OY	454	338	316	499	383	362	315	142	116	47	251	168	235	200	220	4	18	270	13.5	42	110	90	12	8	5	M16x32L	
SGMGH-1ED@A6@-OY	573	457	435	635	519	497	415			48	343													16	10	6	M20x40L

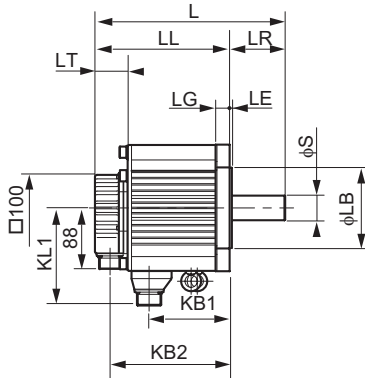

Models without Brake

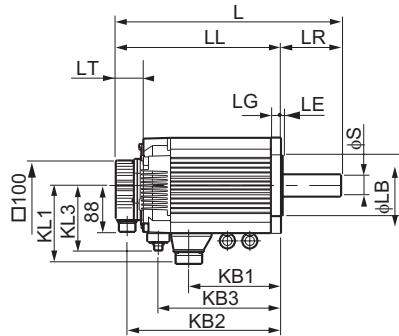

Models with Brake

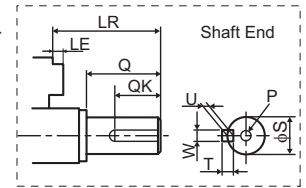
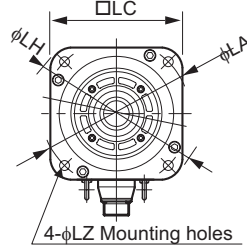

Type SGMSh (400V)

Dimensions (mm)	Without Brake			With Brake				LR	LT	KB1	KL1	Flange surface							Shaft end							
	L	LL	KB2	L	LL	KB2	KB3					KL3	LA	LB	LC	LE	LG	LH	LZ	S	Q	QK	W	T	U	P
SGMSh-10D@A6@-OY	194	149	128	238	193	171	120	85	45	46	76	96	115	95 ^{h7}	100	3	10	130	7	24 ^{h6}	40	32	8	7	4	M8x16L
SGMSh-15D@A6@-OY	220	175	154	264	219	197	146				102															
SGMSh-20D@A6@-OY	243	198	177	287	242	220	169				125															
SGMSh-30D@A6@-OY	262	199	178	300	237	216	170	98	63		124	114	145	110 ^{h7}	130	6	12	165	9	28 ^{h6}	55	50				
SGMSh-40D@A6@-OY	299	236	215	337	274	253	207				161															
SGMSh-50D@A6@-OY	339	276	255	377	314	293	247				201															

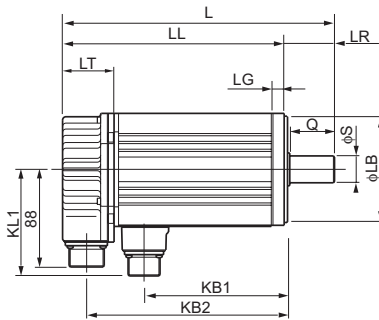

Models without Brake

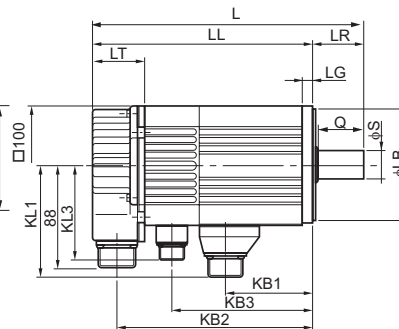

Models with Brake

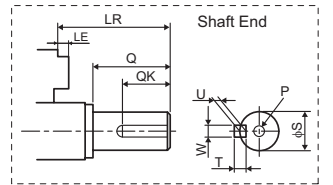
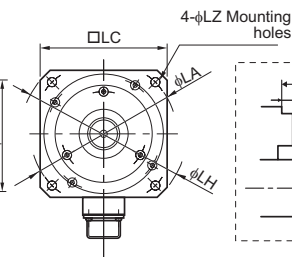

Type SGMUH (400V)

Dimensions (mm)	Without Brake			With Brake					LR	LT	KB1	KL1	Flange surface							Shaft end						
	L	LL	KB2	L	LL	KB2	KB3	KL3					LA	LB	LC	LE	LG	LH	LZ	S	Q	QK	W	T	U	P
SGMUH-10D@A6@-OY	194	149	128	238	193	171	120	85	45	46	76	96	130	110	116	3.5	10	150	9	24 ^{h6}	40	32	8	7	4	M8x16L
SGMUH-15D@A6@-OY	220	175	154	264	219	197	146				102															
SGMUH-30D@A6@-OY	262	202	181	300	237	219	173	98	60		127	114	165	130	155		12	190	11	28 ^{h6}	55	50				
SGMUH-40D@A6@-OY	327	269	245	362	302	281	210				164															

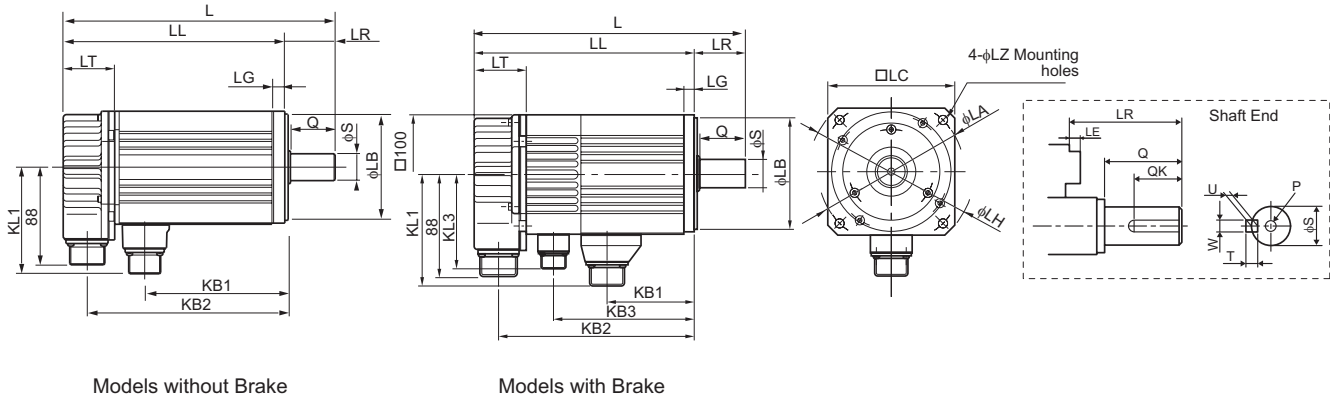

Servodrives

SGDH-A3AE-OY to -02AE-OY (230V, 30 to 200W)

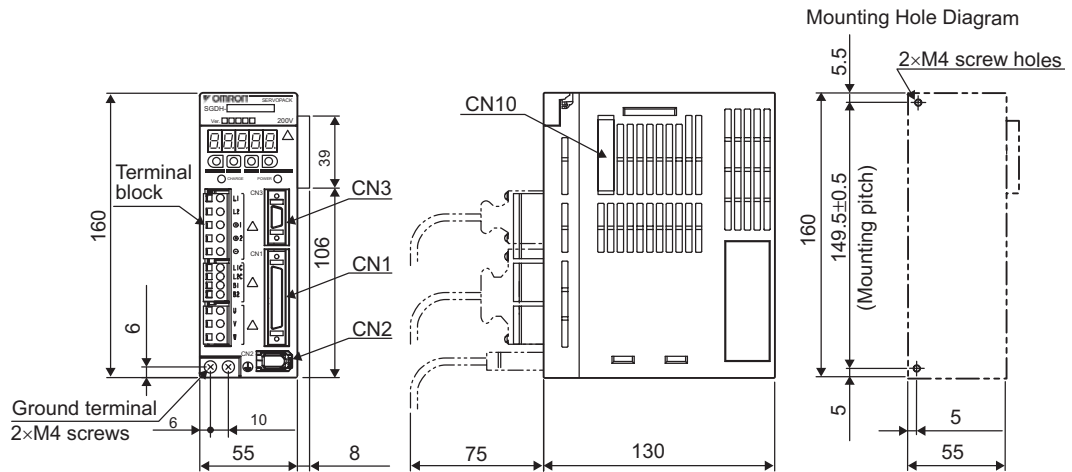

SGDH-04AE-OY (230V, 400W)

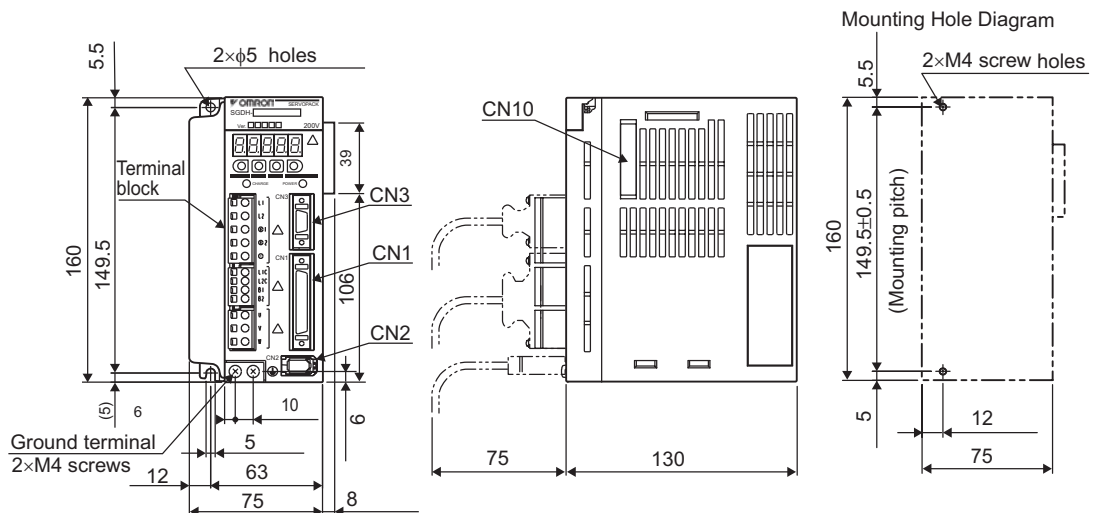

SGDH-08AE-S-OY (230V, 750W)

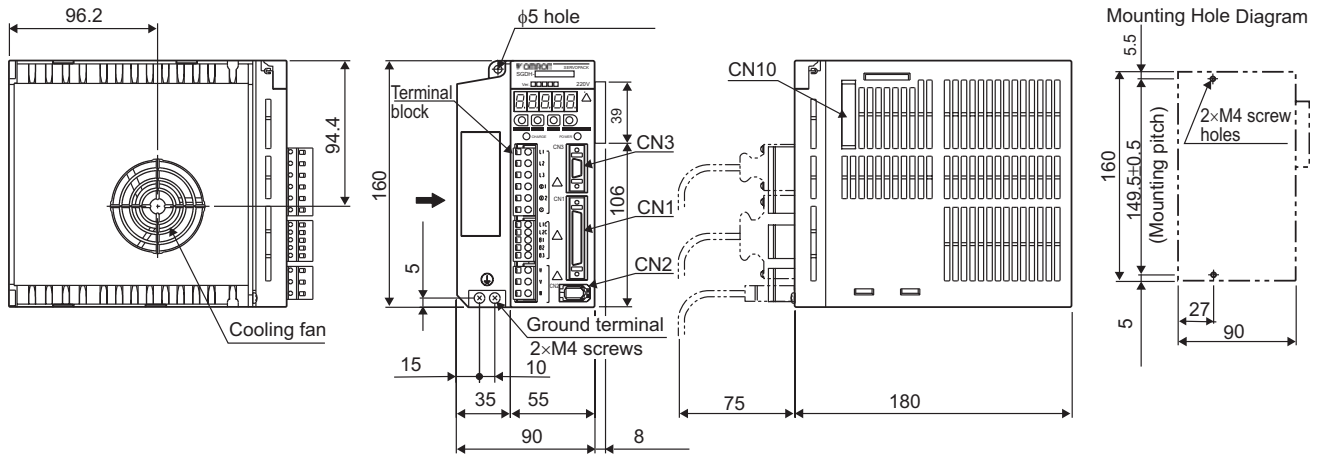

SGDH-05DE-OY to -15DE-OY (400V, 0.5 to 1.5kW)

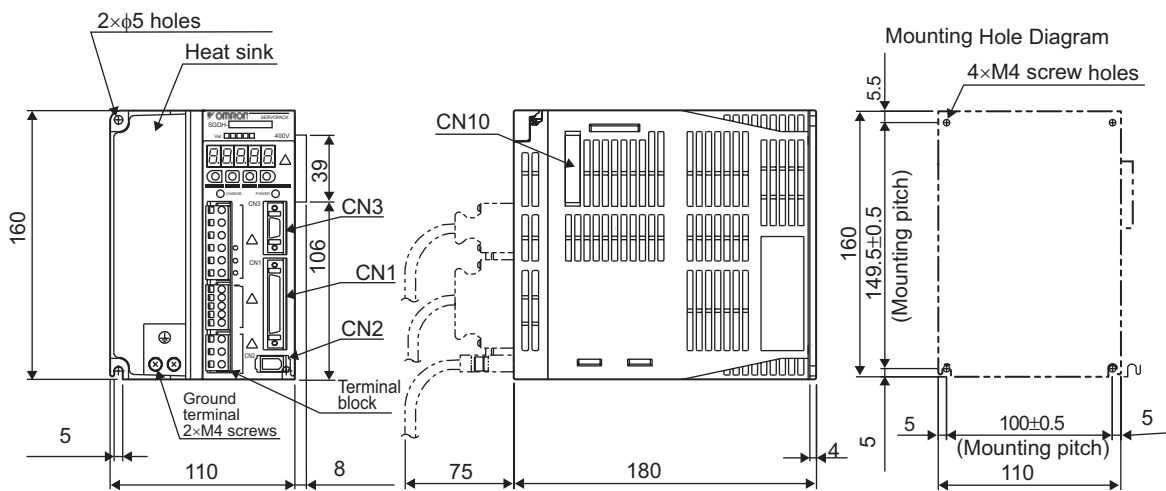

SGDH-15AE-S (230V, 1.5 kW)

SGDH-20/30DE-OY (400V, 2/3kW)

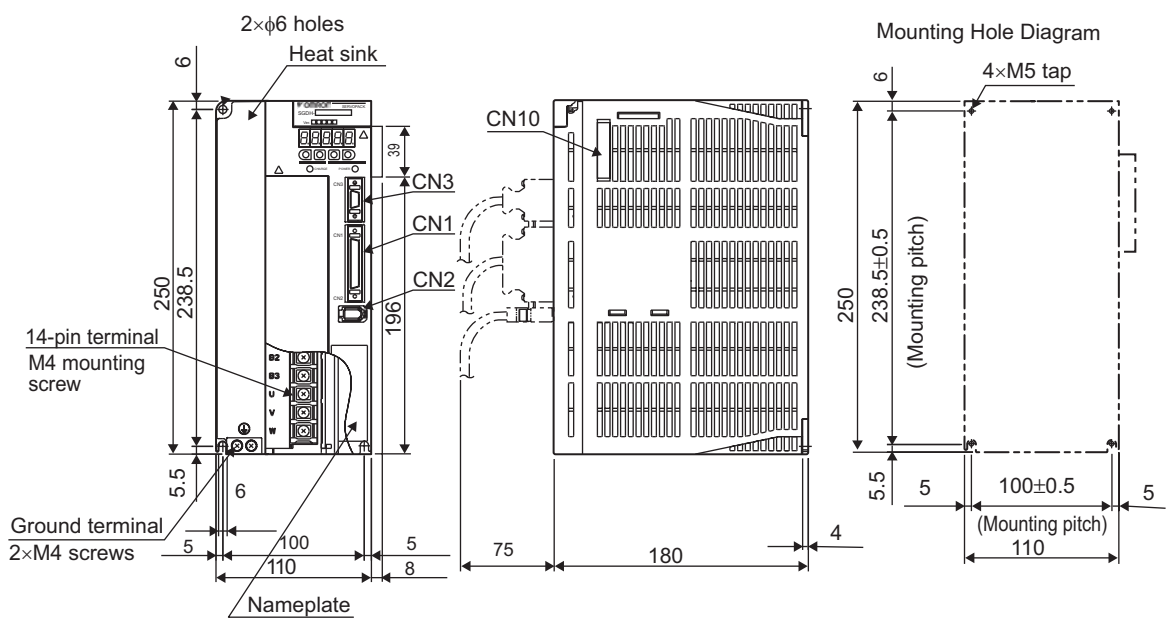

SGDH-50DE-OY (400V, 5kW)

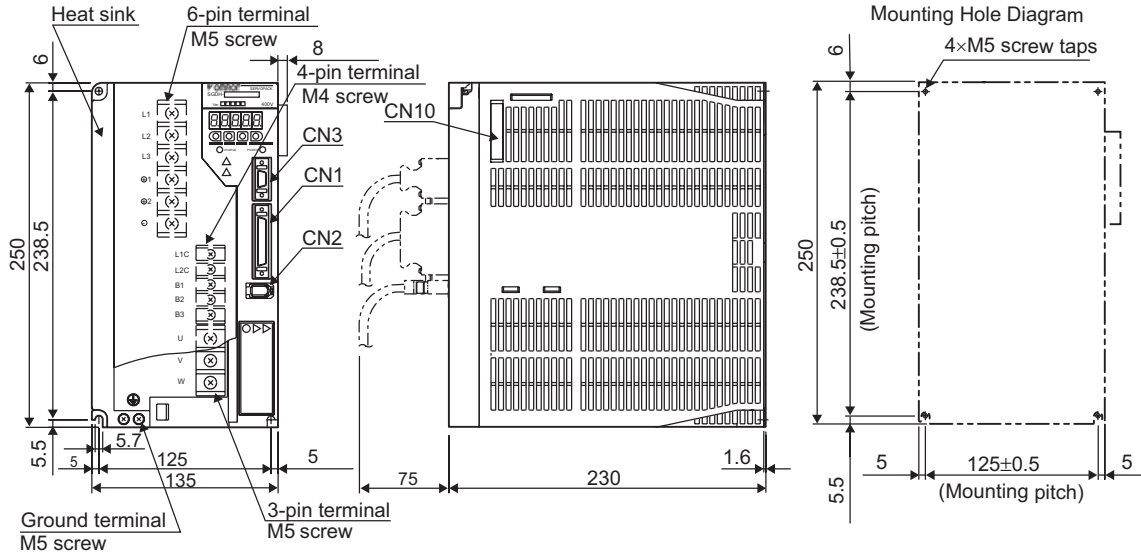

SGDH-60/75DE-OY (400V, 6/7.5kW)

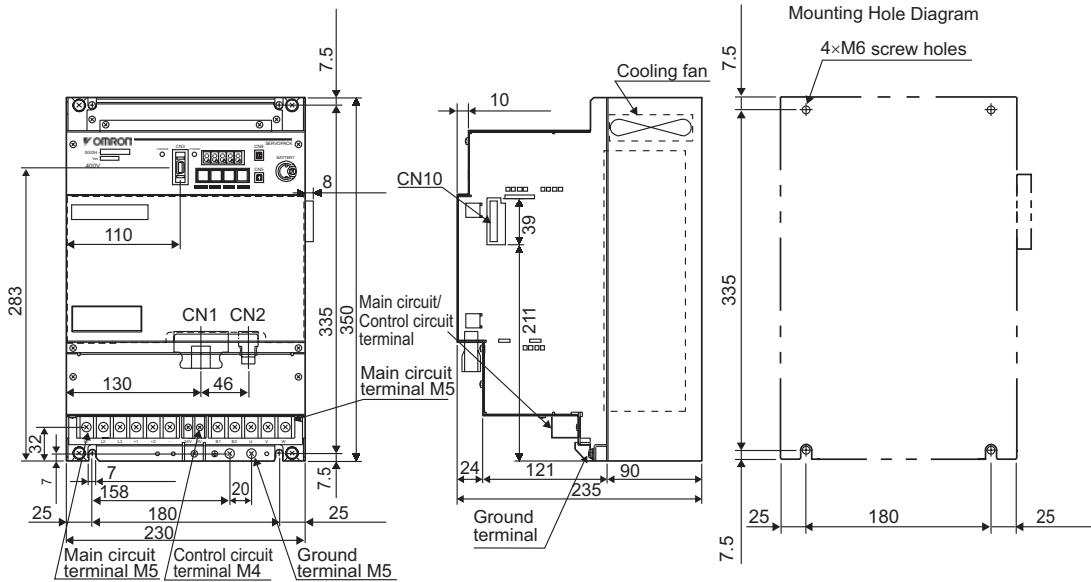

SGDH-1A/1EDE-OY (400V, 11/15kW)

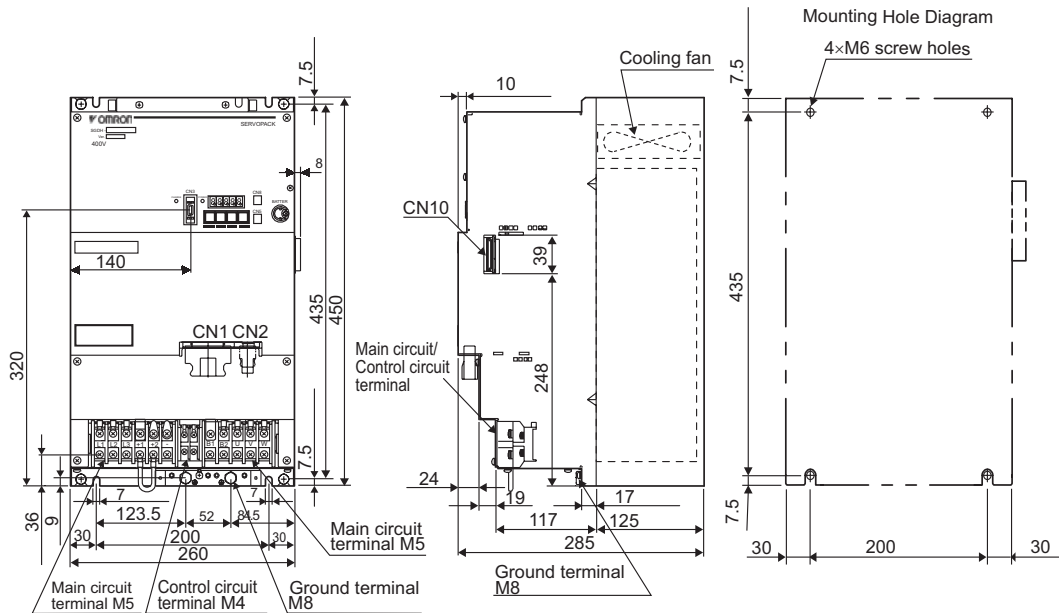

R88A-FIW4020-SE

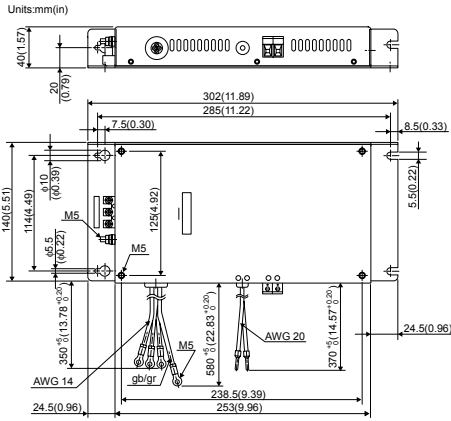

R88A-FIW4030-SE

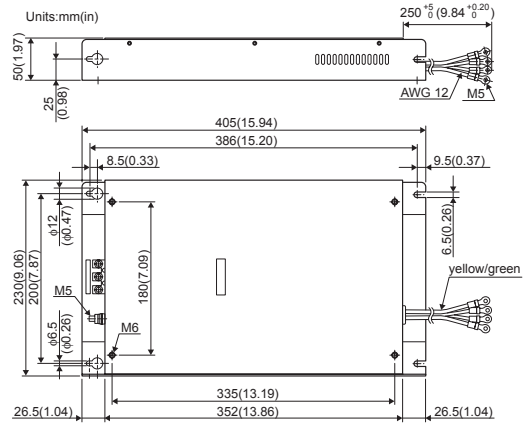

R88A-FIW4055-SE

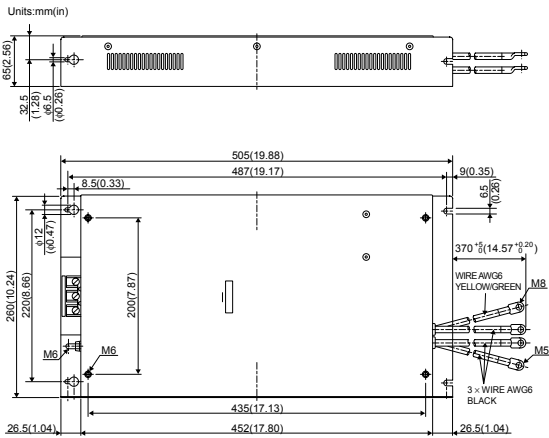

Regenerative Resistor Units

Model	W	H	D	M1	M2	Approx. Mass kg
JUSP-RA18	220	350	92	180	335	4
JUSP-RA19	300	350	95	250	335	7

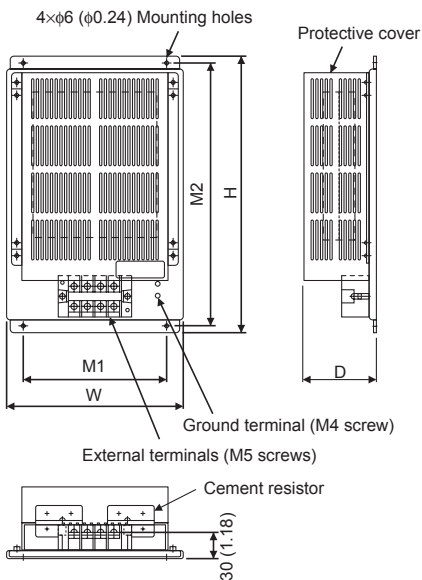

Digital Operator

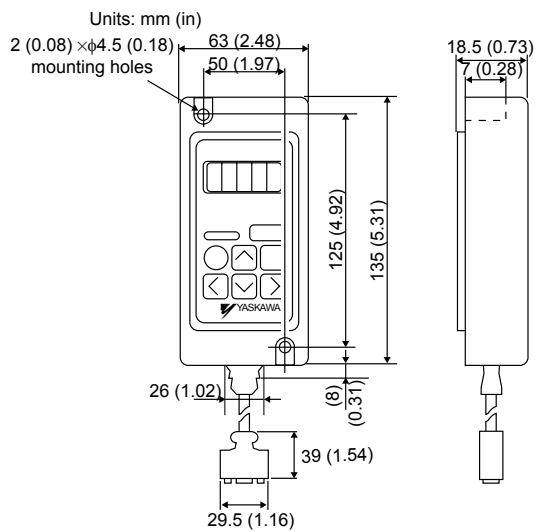

Three-phase, 400VAC

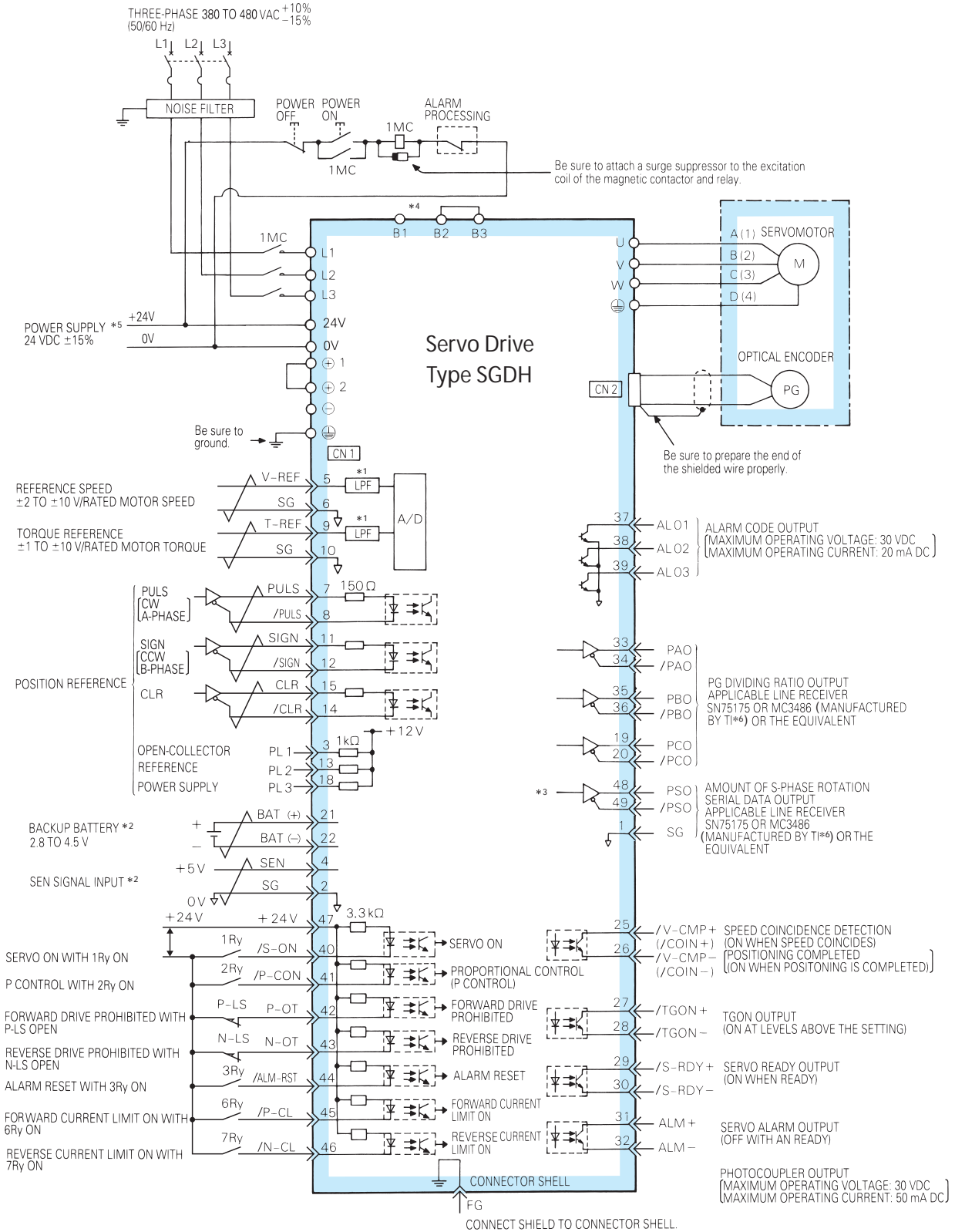

- *1 The time constant for the primary filter is 47 μ s.
- *2 Connect when using an absolute encoder.
- *3 Used only with an absolute encoder.
- *4 For using an external regenerative resistor, connect it between B1 and B2.
(Be sure to connect a regenerative resistor unit to ServoDrive of 6/7.5/11/15kW)
- *5 It is the user's responsibility to obtain 24VDC power supply.
- *6 TI stands for Texas Instruments Inc.

Ordering Information

System Configuration

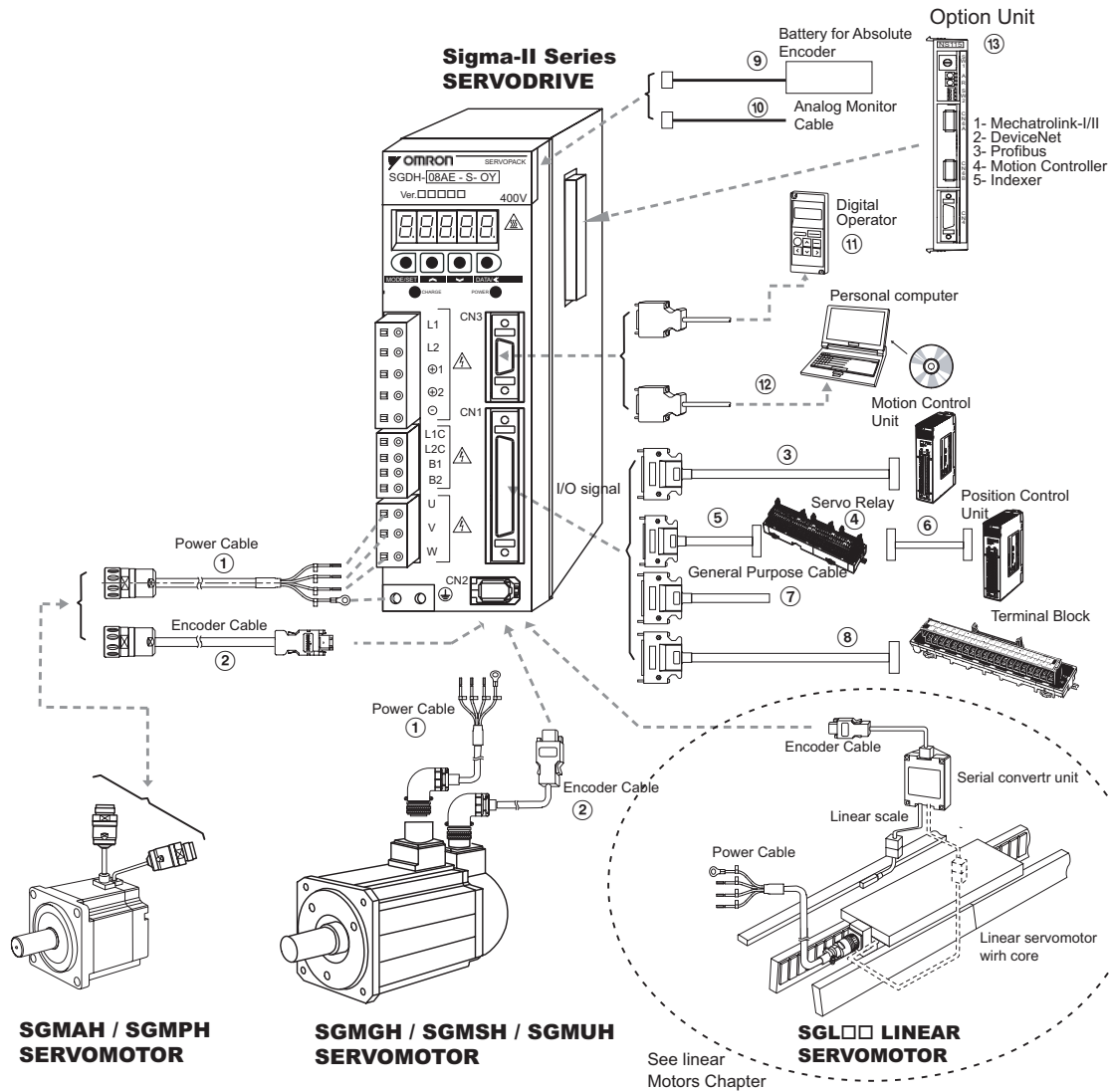

Servo Drives

Specifications	Model	Compatible Servomotors	Linear Motors
1 Phase 200 V AC	30 W	SGDH-A3AE-OY	SGMAH-A3A@
	50 W	SGDH-A5AE-OY	SGMAH-A5D@
	100 W	SGDH-01AE-OY	SGMAH-01A@, SGMPh-01A@
	200 W	SGDH-02AE-OY	SGMAH-02A@, SGMPh-02A@
	400 W	SGDH-04AE-OY	SGMAH-04A@, SGMPh-04A@
	750 W	SGDH-08AE-S-OY	SGMAH-08A@, SGMPh-08A@
	1500 W	SGDH-15AE-S-OY	SGMPh-15A@
	3 Phase 400 V AC	0.5 kW	SGDH-05DE-OY
1.0 kW		SGDH-10DE-OY	SGMGH-09D@, SGMSh/UH-10D@, SGMAH-07D@, SGMPh-08D@
1.5 kW		SGDH-15DE-OY	SGMGH-13D@, SGMSh/UH-15D@, SGMPh-15D@
2.0 kW		SGDH-20DE-OY	SGMGH-20D@, SGMSh-20D@
3.0 kW		SGDH-30DE-OY	SGMGH-30D@, SGMSh/UH-30D@
5.0 kW		SGDH-50DE-OY	SGMGH-44D@, SGMSh/UH-40D@, SGMSh-50D@
6.0 kW		SGDH-60DE-OY	SGMGH-55D@
7.5 kW		SGDH-75DE-OY	SGMGH-75D@
11.0 kW		SGDH-1ADE-OY	SGMGH-1AD@
15.0 kW		SGDH-1EDE-OY	SGMGH-1ED@
			SGLFW-50D200@, SGLTW-35D170@, SGLTW-50D170@
			SGLFW-50D380@, SGLFW-1ZD200@
			SGLTW-35D320@, SGLTW-50D320@
			SGLFW-1ZD380@, SGLTW-40D400@
			SGLTW-40D60@, SGLTW-80D400@
			SGLTW-80D600@

Note: SGLGW-@ Linear motor combination is made considering the use of Standard Magnets. Refer to the Linear motors chapter for details.

200 V Servomotors

SGMAH - Cylindrical Servomotors 3000 r/min (30 - 750 W)



Specifications				Model
Incremental Encoder (13 bit) Straight shaft with key & Tap	Without brake	0.096 Nm	30 W	SGMAH-A3AAA61D-OY
		0.159 Nm	50 W	SGMAH-A5AAA61D-OY
		0.318 Nm	100 W	SGMAH-01AAA61D-OY
		0.637 Nm	200 W	SGMAH-02AAA61D-OY
		1.27 Nm	400 W	SGMAH-04AAA61D-OY
		2.39 Nm	750 W	SGMAH-08AAA61D-OY
	With brake	0.096 Nm	30 W	SGMAH-A3AAA6CD-OY
		0.159 Nm	50 W	SGMAH-A5AAA6CD-OY
		0.318 Nm	100 W	SGMAH-01AAA6CD-OY
		0.637 Nm	200 W	SGMAH-02AAA6CD-OY
		1.27 Nm	400 W	SGMAH-04AAA6CD-OY
		2.39 Nm	750 W	SGMAH-08AAA6CD-OY
Absolute Encoder (16 bit) Straight shaft with key & Tap	Without brake	0.096 Nm	30 W	SGMAH-A3A1A61D-OY
		0.159 Nm	50 W	SGMAH-A5A1A61D-OY
		0.318 Nm	100 W	SGMAH-01A1A61D-OY
		0.637 Nm	200 W	SGMAH-02A1A61D-OY
		1.27 Nm	400 W	SGMAH-04A1A61D-OY
		2.39 Nm	750 W	SGMAH-08A1A61D-OY
	With brake	0.096 Nm	30 W	SGMAH-A3A1A6CD-OY
		0.159 Nm	50 W	SGMAH-A5A1A6CD-OY
		0.318 Nm	100 W	SGMAH-01A1A6CD-OY
		0.637 Nm	200 W	SGMAH-02A1A6CD-OY
		1.27 Nm	400 W	SGMAH-04A1A6CD-OY
		2.39 Nm	750 W	SGMAH-08A1A6CD-OY

SGMPH - Flat Type Servomotors 3000 r/min (100 - 1500 W)



Specifications				Model		
Incremental Encoder (13 bit) Straight shaft with key & Tap	Without brake	0.318 Nm	100 W	SGMPH-01AAA61D-OY		
		0.637 Nm	200 W	SGMPH-02AAA61D-OY		
		1.27 Nm	400 W	SGMPH-04AAA61D-OY		
		2.39 Nm	750 W	SGMPH-08AAA61D-OY		
		4.77 Nm	1500 W	SGMPH-15AAA61D-OY		
		0.318 Nm	100 W	SGMPH-01AAA6CD-OY		
	With brake	0.637 Nm	200 W	SGMPH-02AAA6CD-OY		
		1.27 Nm	400 W	SGMPH-04AAA6CD-OY		
		2.39 Nm	750 W	SGMPH-08AAA6CD-OY		
		4.77 Nm	1500 W	SGMPH-15AAA6CD-OY		
		Absolute Encoder (16 bit) Straight shaft with key & Tap	Without brake	0.318 Nm	100 W	SGMPH-01A1A61D-OY
				0.637 Nm	200 W	SGMPH-02A1A61D-OY
1.27 Nm	400 W			SGMPH-04A1A61D-OY		
2.39 Nm	750 W			SGMPH-08A1A61D-OY		
4.77 Nm	1500 W			SGMPH-15A1A61D-OY		
0.318 Nm	100 W			SGMPH-01A1A6CD-OY		
With brake	0.637 Nm		200 W	SGMPH-02A1A6CD-OY		
	1.27 Nm		400 W	SGMPH-04A1A6CD-OY		
	2.39 Nm		750 W	SGMPH-08A1A6CD-OY		
	4.77 Nm		1500 W	SGMPH-15A1A6CD-OY		

400 V Servomotors

SGMAH - Cyl. Servomotors 3000 r/min (300 - 650 W)



Specifications				Model		
Incremental Encoder (13 bit) Straight shaft with key	Without brake	0.955 Nm	300 W	SGMAH-03DAA61D-OY		
		2.07 Nm	650 W	SGMAH-07DAA61D-OY		
		0.955 Nm	300 W	SGMAH-03DAA6CD-OY		
	With brake	2.07 Nm	650 W	SGMAH-07DAA6CD-OY		
		Absolute Encoder (16 bit) Straight shaft with key	Without brake	0.955 Nm	300 W	SGMAH-03D1A61D-OY
				2.07 Nm	650 W	SGMAH-07D1A61D-OY
0.955 Nm	300 W			SGMAH-03D1A6CD-OY		
With brake	2.07 Nm		650 W	SGMAH-07D1A6CD-OY		

SGMPH - Flat Type Servomotors 3000 r/min (0.2 - 1.5 kW)



Specifications				Model		
Incremental Encoder (13 bit) Straight shaft with key	Without brake	0.637 Nm	200 W	SGMPH-02DAA61D-OY		
		1.27 Nm	400 W	SGMPH-04DAA61D-OY		
		2.39 Nm	750 W	SGMPH-08DAA61D-OY		
		4.77 Nm	1500 W	SGMPH-15DAA61D-OY		
		With brake	0.637 Nm	200 W	SGMPH-02DAA6CD-OY	
			1.27 Nm	400 W	SGMPH-04DAA6CD-OY	
	2.39 Nm		750 W	SGMPH-08DAA6CD-OY		
	4.77 Nm		1500 W	SGMPH-15DAA6CD-OY		
	Absolute Encoder (16 bit) Straight shaft with key		Without brake	0.637 Nm	200 W	SGMPH-02D1A61D-OY
				1.27 Nm	400 W	SGMPH-04D1A61D-OY
		2.39 Nm		750 W	SGMPH-08D1A61D-OY	
		4.77 Nm		1500 W	SGMPH-15D1A61D-OY	
With brake		0.637 Nm		200 W	SGMPH-02D1A6CD-OY	
		1.27 Nm		400 W	SGMPH-04D1A6CD-OY	
		2.39 Nm	750 W	SGMPH-08D1A6CD-OY		
		4.77 Nm	1500 W	SGMPH-15D1A6CD-OY		

400V Servomotors

SGMGH - Servomotors 1500 r/min (0.45 - 15 kW)

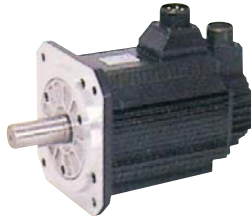

Specifications				Model
Incremental Encoder (17 bit) Straight shaft with key & Tap	Without brake	2.84 Nm	0.45 kW	SGMGH-05DCA6F-OY
		5.39 Nm	0.85 kW	SGMGH-09DCA6F-OY
		8.34 Nm	1.3 kW	SGMGH-13DCA6F-OY
		11.5 Nm	1.8 kW	SGMGH-20DCA6F-OY
		18.6 Nm	2.9 kW	SGMGH-30DCA6F-OY
		28.4 Nm	4.4 kW	SGMGH-44DCA6F-OY
		35.0 Nm	5.5 kW	SGMGH-55DCA6F-OY
		48.0 Nm	7.5 kW	SGMGH-75DCA6F-OY
		70.0 Nm	11.5 kW	SGMGH-1ADCA6F-OY
		95.4 Nm	15.0 kW	SGMGH-1EDCA6F-OY
	With brake	2.84 Nm	0.45 kW	SGMGH-05DCA6H-OY
		5.39 Nm	0.85 kW	SGMGH-09DCA6H-OY
		8.34 Nm	1.3 kW	SGMGH-13DCA6H-OY
		11.5 Nm	1.8 kW	SGMGH-20DCA6H-OY
		18.6 Nm	2.9 kW	SGMGH-30DCA6H-OY
		28.4 Nm	4.4 kW	SGMGH-44DCA6H-OY
		35.0 Nm	5.5 kW	SGMGH-55DCA6H-OY
		48.0 Nm	7.5 kW	SGMGH-75DCA6H-OY
		70.0 Nm	11.5 kW	SGMGH-1ADCA6H-OY
95.4 Nm	15.0 kW	SGMGH-1EDCA6H-OY		
Absolute Encoder (17 bit) Straight shaft with key & Tap	Without brake	2.84 Nm	0.45 kW	SGMGH-05D2A6F-OY
		5.39 Nm	0.85 kW	SGMGH-09D2A6F-OY
		8.34 Nm	1.3 kW	SGMGH-13D2A6F-OY
		11.5 Nm	1.8 kW	SGMGH-20D2A6F-OY
		18.6 Nm	2.9 kW	SGMGH-30D2A6F-OY
		28.4 Nm	4.4 kW	SGMGH-44D2A6F-OY
		35.0 Nm	5.5 kW	SGMGH-55D2A6F-OY
		48.0 Nm	7.5 kW	SGMGH-75D2A6F-OY
		70.0 Nm	11.5 kW	SGMGH-1AD2A6F-OY
		95.4 Nm	15.0 kW	SGMGH-1ED2A6F-OY
	With brake	2.84 Nm	0.45 kW	SGMGH-05D2A6H-OY
		5.39 Nm	0.85 kW	SGMGH-09D2A6H-OY
		8.34 Nm	1.3 kW	SGMGH-13D2A6H-OY
		11.5 Nm	1.8 kW	SGMGH-20D2A6H-OY
		18.6 Nm	2.9 kW	SGMGH-30D2A6H-OY
		28.4 Nm	4.4 kW	SGMGH-44D2A6H-OY
		35.0 Nm	5.5 kW	SGMGH-55D2A6H-OY
		48.0 Nm	7.5 kW	SGMGH-75D2A6H-OY
		70.0 Nm	11.5 kW	SGMGH-1AD2A6H-OY
95.4 Nm	15.0 kW	SGMGH-1ED2A6H-OY		

SGMSH - Servomotors 3000 r/min (1 - 5 kW)



Specifications				Model		
Incremental Encoder (17 bit) Straight shaft with key & Tap	Without brake	3.18 Nm	1.0 kW	SGMSH-10DCA6F-OY		
		4.9 Nm	1.5 kW	SGMSH-15DCA6F-OY		
		6.36 Nm	2.0 kW	SGMSH-20DCA6F-OY		
		9.8 Nm	3.0 kW	SGMSH-30DCA6F-OY		
		12.6 Nm	4.0 kW	SGMSH-40DCA6F-OY		
		15.8 Nm	5.0 kW	SGMSH-50DCA6H-OY		
	With brake	3.18 Nm	1.0 kW	SGMSH-10DCA6H-OY		
		4.9 Nm	1.5 kW	SGMSH-15DCA6H-OY		
		6.36 Nm	2.0 kW	SGMSH-20DCA6H-OY		
		9.8 Nm	3.0 kW	SGMSH-30DCA6H-OY		
		12.6 Nm	4.0 kW	SGMSH-40DCA6H-OY		
		15.8 Nm	5.0 kW	SGMSH-50DCA6H-OY		
		Absolute Encoder (17 bit) Straight shaft with key & Tap	Without brake	3.18 Nm	1.0 kW	SGMSH-10D2A6F-OY
				4.9 Nm	1.5 kW	SGMSH-15D2A6F-OY
6.36 Nm	2.0 kW			SGMSH-20D2A6F-OY		
9.8 Nm	3.0 kW			SGMSH-30D2A6F-OY		
12.6 Nm	4.0 kW			SGMSH-40D2A6F-OY		
15.8 Nm	5.0 kW			SGMSH-50D2A6H-OY		
With brake	3.18 Nm		1.0 kW	SGMSH-10D2A6H-OY		
	4.9 Nm		1.5 kW	SGMSH-15D2A6H-OY		
	6.36 Nm		2.0 kW	SGMSH-20D2A6H-OY		
	9.8 Nm		3.0 kW	SGMSH-30D2A6H-OY		
12.6 Nm	4.0 kW	SGMSH-40D2A6H-OY				
15.8 Nm	5.0 kW	SGMSH-50D2A6H-OY				

SGMUH - Servomotors 6000 r/min (1 - 4 kW)



Specifications				Model
Incremental Encoder (17 bit) Straight shaft with key	Without brake	1.59 Nm	1.0 kW	SGMUH-10DCA61-OY
		2.45 Nm	1.5 kW	SGMUH-15DCA61-OY
		4.9 Nm	3.0 kW	SGMUH-30DCA61OY
		6.3 Nm	4.0 kW	SGMUH-40DCA61-OY
	With brake	1.59 Nm	1.0 kW	SGMUH-10DCA6C-OY
		2.45 Nm	1.5 kW	SGMUH-15DCA6C-OY
		4.9 Nm	3.0 kW	SGMUH-30DCA6C-OY
		6.3 Nm	4.0 kW	SGMUH-40DCA6C-OY

Power Cables

Symbol	Specifications	Model	Appearance	
①	For 200V Servomotors without brake SGMAH-@@A@@@1D-OY SGMPH-(01/02/04/08)A@@41D-OY	3 m	R88A-CAWA003S-DE	
		5 m	R88A-CAWA005S-DE	
		10 m	R88A-CAWA010S-DE	
		15 m	R88A-CAWA015S-DE	
		20 m	R88A-CAWA020S-DE	
	For 200V Servomotors with brake SGMAH-@@A@@@CD-OY SGMPH-(01/02/04/08)A@@4CD-OY	3 m	R88A-CAWA003B-DE	
		5 m	R88A-CAWA005B-DE	
		10 m	R88A-CAWA010B-DE	
		15 m	R88A-CAWA015B-DE	
		20 m	R88A-CAWA020B-DE	
	For 200V Servomotors without brake SGMPH-15A@@@1D-OY	3 m	R88A-CAWB003S-DE	
		5 m	R88A-CAWB005S-DE	
		10 m	R88A-CAWB010S-DE	
		15 m	R88A-CAWB015S-DE	
		20 m	R88A-CAWB020S-DE	
	For 200V Servomotors with brake SGMPH-15A@@@CD-OY	3 m	R88A-CAWB003B-DE	
		5 m	R88A-CAWB005B-DE	
		10 m	R88A-CAWB010B-DE	
		15 m	R88A-CAWB015B-DE	
		20 m	R88A-CAWB020B-DE	
For 400V Servomotors without brake SGMAH-@@D@@@1D-OY SGMPH-@@D@@@1D-OY	3 m	R88A-CAWK003S-DE		
	5 m	R88A-CAWK005S-DE		
	10 m	R88A-CAWK010S-DE		
	15 m	R88A-CAWK015S-DE		
	20 m	R88A-CAWK020S-DE		
For 400V Servomotors with brake SGMAH-@@D@@@CD-OY SGMPH-@@D@@@CD-OY	3 m	R88A-CAWK003B-DE		
	5 m	R88A-CAWK005B-DE		
	10 m	R88A-CAWK010B-DE		
	15 m	R88A-CAWK015B-DE		
	20 m	R88A-CAWK020B-DE		
For 400V Servomotors SGMGH-(05/09/13)D@ SGMSH-(10/15/20)D@ SGMUH-(10/15)D@ For servomotors with Brake a separate cable (R88A-CAWC0@@B-E) is needed	3 m	R88A-CAWC003S-E		
	5 m	R88A-CAWC005S-E		
	10 m	R88A-CAWC010S-E		
	15 m	R88A-CAWC015S-E		
	20 m	R88A-CAWC020S-E		
For 400V Servomotors SGMGH-(20/30)D@ SGMSH-(30/40/50)D@ SGMUH-(30/40)D@ For servomotors with Brake a separate cable (R88A-CAWC0@@B-E) is needed	3 m	R88A-CAWD003S-E		
	5 m	R88A-CAWD005S-E		
	10 m	R88A-CAWD010S-E		
	15 m	R88A-CAWD015S-E		
	20 m	R88A-CAWD020S-E		
For 400V Servomotors SGMGH-44D@ For servomotors with Brake a separate cable (R88A-CAWC0@@B-E) is needed	3 m	R88A-CAWG003S-E		
	5 m	R88A-CAWG005S-E		
	10 m	R88A-CAWG010S-E		
	15 m	R88A-CAWG015S-E		
	20 m	R88A-CAWG020S-E		
For 400V Servomotors SGMGH-55D@ For servomotors with Brake a separate cable (R88A-CAWC0@@B-E) is needed	3 m	R88A-CAWF003S-E		
	5 m	R88A-CAWF005S-E		
	10 m	R88A-CAWF010S-E		
	15 m	R88A-CAWF015S-E		
	20 m	R88A-CAWF020S-E		
For 400V Servomotors SGMGH-(75/1A)D@ For servomotors with Brake a separate cable (R88A-CAWC0@@B-E) is needed	3 m	R88A-CAWH003S-E		
	5 m	R88A-CAWH005S-E		
	10 m	R88A-CAWH010S-E		
	15 m	R88A-CAWH015S-E		
	20 m	R88A-CAWH020S-E		
For 400V Servomotors SGMGH-1ED@ For servomotors with Brake a separate cable (R88A-CAWC0@@B-E) is needed	3 m	R88A-CAWJ003S-E		
	5 m	R88A-CAWJ005S-E		
	10 m	R88A-CAWJ010S-E		
	15 m	R88A-CAWJ015S-E		
	20 m	R88A-CAWJ020S-E		
Brake Cable only. For 400V Servomotors with Brake SGMGH-@@D@ SGMSH-@@D@ SGMUH-@@D@	3 m	R88A-CAWC003B-E		
	5 m	R88A-CAWC005B-E		
	10 m	R88A-CAWC010B-E		
	15 m	R88A-CAWC015B-E		
		20 m	R88A-CAWC020B-E	

Encoder Cables (for CN2)

Symbol	Specifications	Model	Appearance	
②	Encoder cable for SGM/AH/PH Servomotors SGMAH-@@@@@D-OY SGMAP-@@@@@D-OY	3 m	R88A-CRWA003C-DE	
		5 m	R88A-CRWA005C-DE	
		10 m	R88A-CRWA010C-DE	
		15 m	R88A-CRWA015C-DE	
		20 m	R88A-CRWA020C-DE	
	Encoder cable for SGM/GH/SH/UH/BH Servomotors SGMGH-@ SGMSH-@ SGMUH-@	3 m	R88A-CRWB003N-E	
		5 m	R88A-CRWB005N-E	
		10 m	R88A-CRWB010N-E	
		15 m	R88A-CRWB015N-E	
		20 m	R88A-CRWB020N-E	

Control Cables (for CN1)

Symbol	Description	Connect to	Model		
③	Control Cable (1 Axis)	Motion Control Units CS1W-MC221 CS1W-MC421 C200H-MC221	1 m	R88A-CPW001M1	
			2 m	R88A-CPW002M1	
			3 m	R88A-CPW003M1	
			5 m	R88A-CPW005M1	
			1 m	R88A-CPW001M2	
	Control Cable (2 Axis)	Motion Control Units CS1W-MC221 CS1W-MC421 C200H-MC221	2 m	R88A-CPW002M2	
			3 m	R88A-CPW003M2	
			5 m	R88A-CPW005M2	
			-	R88A-TC04-E	
	Terminal Block (4 Axes)	Motion Control Unit C200HW-MC402-E	1 M	R88A-CMUK001J3-E2	
Servodrive connecting Cable (1 Axis)	1 m		R88A-CMX001S-E		
PLC Unit Control Cables (4 Axes)	1 m		R88A-CMX001J1-E		
④	Servo Relay Unit	CS1W-NC1@3, CJ1W-NC1@3, or C200HW-NC113 Position Control Unit	XW2B-20J6-1B (1 axis)		
		CS1W-NC2@3/4@3, CJ1W-NC2@3/4@3, or C200HW-NC213/413 Position Control Unit	XW2B-40J6-2B (2 axes)		
		CQM1H-PLB21 CQM1-CPU43	XW2B-20J6-3B (1 axis)		
		CJ1M-CPU22/23	XW2B-20J6-8A (1 axis) XW2B-40J6-9A (2 axes)		
		⑤	Cable to Servo drive	Servo Relay Units XW2B-@0J6-@B	1 m XW2Z-100J-B4 2 m XW2Z-200J-B4
⑥	Position Control Unit Connecting Cable	C200H-NC112	0.5 m XW2Z-050J-A1 1 m XW2Z-100J-A1		
		C200H-NC211	0.5 m XW2Z-050J-A2 1 m XW2Z-100J-A2		
		CQM1-CPU43-V1 and CQM1H-PLB21	0.5 m XW2Z-050J-A3 1 m XW2Z-100J-A3		
		CS1W-NC113 and C200HW-NC113	0.5 m XW2Z-050J-A6 1 m XW2Z-100J-A6		
		CS1W-NC213/413 and C200HW-NC213/413	0.5 m XW2Z-050J-A7 1 m XW2Z-100J-A7		
		CS1W-NC133	0.5 m XW2Z-050J-A10 1 m XW2Z-100J-A10		
		CS1W-NC233/433	0.5 m XW2Z-050J-A11 1 m XW2Z-100J-A11		
		CJ1W-NC113	0.5 m XW2Z-050J-A14 1 m XW2Z-100J-A14		
		CJ1W-NC213/413	0.5 m XW2Z-050J-A15 1 m XW2Z-100J-A15		
		CJ1W-NC133	0.5 m XW2Z-050J-A18 1 m XW2Z-100J-A18		
		CJ1W-NC233/433	0.5 m XW2Z-050J-A19 1 m XW2Z-100J-A19		
		CJ1M-CPU22/23	0.5 m XW2Z-050J-A27 1 m XW2Z-100J-A27		
		⑦	Control Cable	For General purpose Controllers	1 m R88A-CPW001S or JZSP-CKI01-1
					2 m R88A-CPW002S or JZSP-CKI01-1
		⑧	Relay Terminal Block Cable	General-purpose Controller	1 m R88A-CTW001N
			Relay Terminal Block		2 m R88A-CTW002N - XW2B-50G5

Battery Backup for absolute encoder (for CN8)

Symbol	Name	Model
⑨	Battery for 30W to 5 kW Drives	JZSP-BA01
	Battery for 6kW to 15 kW Drives	JZSP-BA01-1

Cable (for CN5)

Symbol	Name	Model
⑩	Analog Monitor Cable	R88A-CMW001S or DE9404559

Options (for CN3)

Symbol	Name	Model
⑪	Parameter Unit with Cable	JUSP-OP02A-2 or R88A-PR02W
⑫	Computer Connecting Cable	R88A-CCW002P2 or JZSP-CMS02

Connectors

Specification	Model
Control I/O connector (For CN1)	R88A-CNU11C or JZSP-CKI9
Sigma-II Drive Encoder connector (For CN2)	JZSP-CMP9-1
Hypertac Power Connector IP67 (For 200V Motors SGMMAH/PH-@@A@@@@D-OY)	SPOC-06K-FSDN169
Hypertac Power Connector IP67 (For 400V Motors SGMMAH/PH-@D@@@@D-OY)	LPRA-06B-FRBN170
Hypertac Encoder Connector IP67 (For Motors SGMMAH/PH-@@@@@D-OY)	SPOC-17H-FRON169
Military Power connector IP67 (For 400V Motors SGMGH-(05/10/13)D@, SGMSh-(10/15/20)D@, SGMUH-(10/15)D@)	MS3108E18-10S
Military Power connector IP67 (For 400V Motors SGMGH-(20/30/44)D@, SGMSh-(30/40/50)D@, SGMUH-(30/40)D@)	MS3108E22-22S
Military Power connector IP67 (For 400V Motors SGMGH-(55/75/1A/1E)D@)	MS3108E32-17S
Military Brake connector IP67 (For 400V ServoMotors SGMGH-@, SGMSh-@, SGMUH-@)	MS3108E10SL-3S
Military Encoder connector IP67 (For Motors SGMGH-@, SGMSh-@, SGMUH-@)	MS3108E20-29S

Filters

Specifications (applicable Servo Drive)	Model	Rated Current	Rated Voltage
SGDH-A3AE-OY,SGDH-A5AE-OY,SGDH-01AE-OY,SGDH-02AE-OY	R88A-FIW104-SE	4 A	250 VAC Single-Phase
SGDH-04AE-OY	R88A-FIW107-SE	7A	
SGDH-08AE-S-OY	R88A-FIW115-SE	15 A	
SGDH-15AE-S-OY	R88A-FIW125-SE	25 A	400 VAC Three-Phase
SGDH-05DE-OY,SGDH-10DE-OY,SGDH-15DE-OY	R88A-FIW4006-SE	6 A	
SGDH-20DE-OY,SGDH-30DE-OY	R88A-FIW4010-SE	10 A	
SGDH-50DE-OY	R88A-FIW4020-SE	20 A	
SGDH-60DE-OY,SGDH-75DE-OY	R88A-FIW4030-SE	30 A	
SGDH-1AE-OY,SGDH-1EDE-OY	R88A-FIW4055-SE	55 A	

External Regenerative Resistor

Servo Drive Model	Regenerative Resistor Unit Model	Specifications	Allowable Power Loss
SGDH-60DE-OY to -75DE-OY	JUSP-RA18	18 Ω , 880 W	180 W
SGDH-1AE-OY to -1EDE-OY	JUSP-RA19	14.25 Ω , 1760 W	350 W

Computer Software

Specifications	Model
SigmaWin	MOTION TOOLS
WMON Win Version 2.0	

Option Units (for CN10)

Symbol	Name	Model
⑬	1.5 axis Advanced Motion Controller with Host Link Interface	R88A-MCW151-E
	1.5 axis Advanced Motion Controller with DeviceNet Interface	R88A-MCW151-DRT-E
	Mechatrolink-I Interface unit	JUSP-NS100
	Mechatrolink-II Interface unit	JUSP-NS115
	DeviceNet Interface unit with Positioning Functionality	JUSP-NS300
	PROFIBUS-DP Interface unit with Positioning Functionality	JUSP-NS500
	Indexer Unit. Versatile Point to Point Positioning	JUSP-NS600